

See *Figure 1, Step 12*, for the Input Power Connector location on the cryopump.

1. Insert flat blade screwdriver into Power Cable Clamp Slot (Slot) and move it away from Power Cable Connector Cap (Cap).

Slot mechanism holds screwdriver in place.

The Power Cable Clamp (Clamp not visible) releases Cap and Locking Tab appears.

2. Remove Cap.
3. Plug Input Power Cable into Input Power Cable Connector on module, and then rotate Connector Collar (not visible) until tight.
4. Remove screwdriver to lower Clamp. This secures Input Power Cable.
5. Connect appropriate ground and leads of Input Power Cable to local **208 VAC, 50/60 Hz Single-Phase, 5 Amp** source.

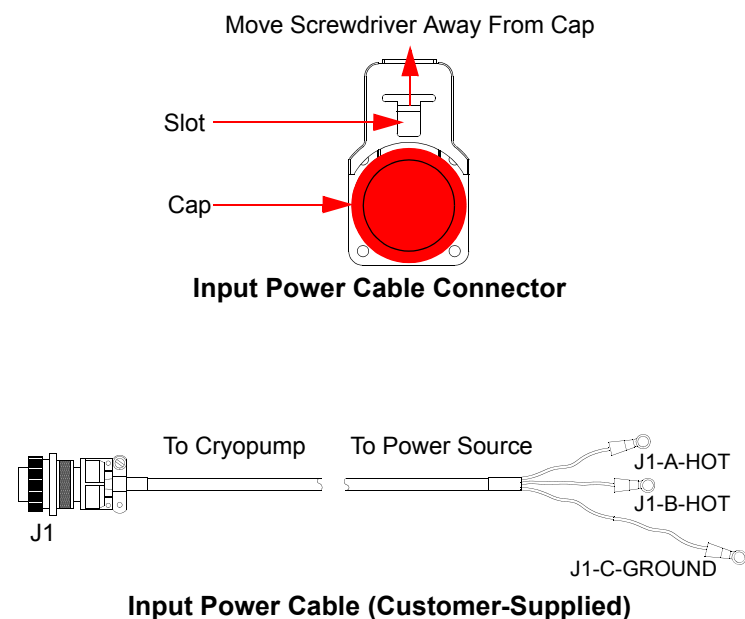

Figure 2: Input Power Cable Connector and Input Power Cable

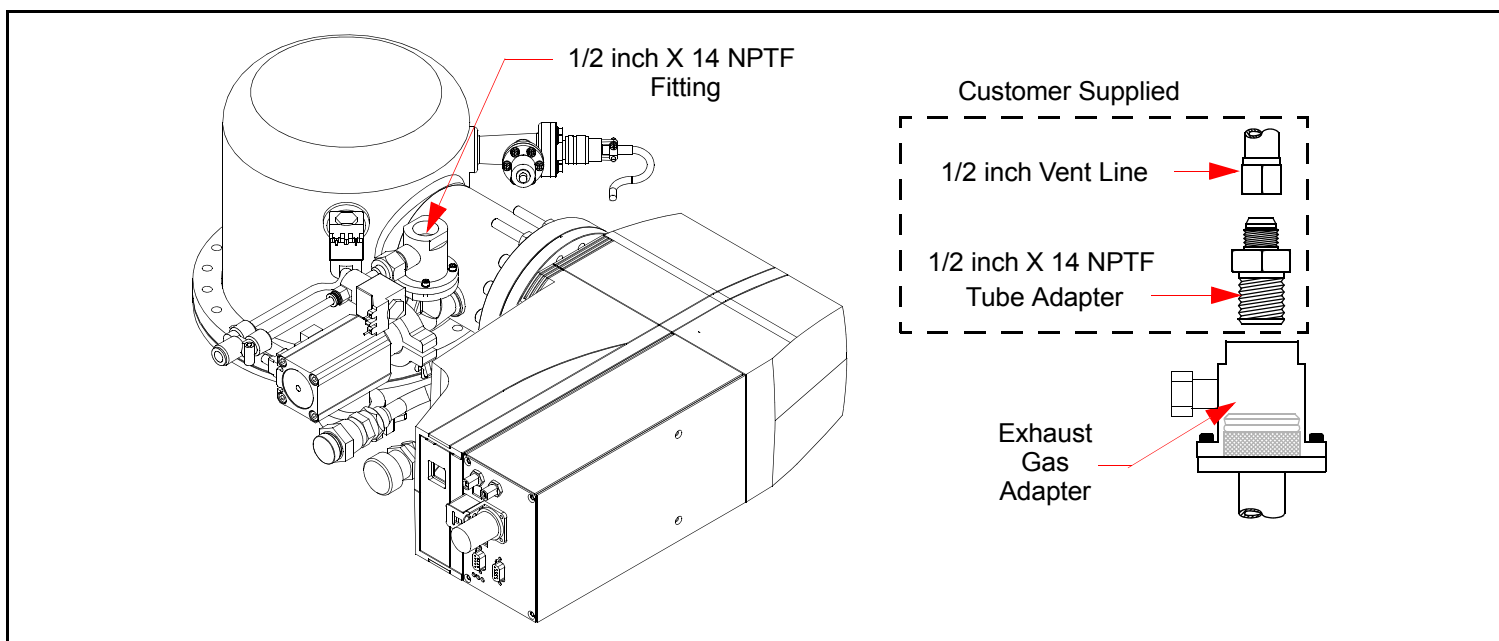

Figure 3: Relief Valve Exhaust Connection

Startup the Cryopump

See 8040647, *On-Board IS Operation Instructions*, for details.

Product Information and Technical Support

Please visit the Brooks Automation website at www.brooks.com or email to tscallcenter@brooks.com.

On-Board® /S 8F Cryopump Quick Installation Guide

Part Number 8040644, Revision 13, 12/10/2007

ECO Number 18207

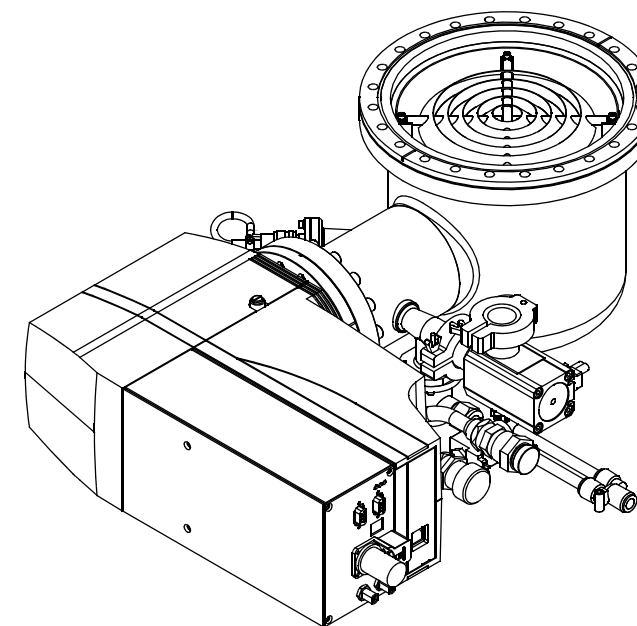

On-Board IS 8F Cryopump Facility Requirements





Electrical Power	Roughing Valve	Air Supply	Nitrogen Purge Gas
208 VAC (Range: 180-253 VAC) 5 Amps 50/60 Hz Single phase	NW-25 ISO KF flange 1/4 inch tube connection	60 - 80 psig 1/4 inch tube connection for exhaust port	60 - 80 psig 3/8 inch tube connection

Before You Start

1. Ensure On-Board IS 1000 Compressors are installed according to 8040645, *On-Board IS 1000 Compressor Quick Installation Guide*.
2. Read and follow all safety notices in this guide and in the appropriate compressor guides.

Cryopump Safety

Ensure the cryopump operates safely and dependably by adhering to all safety notices when you use or service the cryopump.

	<p style="text-align: center;">⚠ WARNING</p> <p style="text-align: center;">Toxic, Corrosive, Flammable or Explosive Materials</p> <ol style="list-style-type: none"> 1. To prevent personal injury, over pressurization, and equipment damage, always vent toxic, corrosive, or flammable materials to a safe location using an inert gas. 2. Clearly identify toxic, corrosive, or flammable materials on shipping containers when you ship equipment that contacted these materials. 3. To prevent flammable gas ignition, do not install a hot filament type vacuum gauge on the high-vacuum side of the isolation valve. 4. To prevent explosions, be aware of ozone as a by-product of an oxygen process and take the appropriate precautions.
	<p style="text-align: center;">⚠ WARNING</p> <p style="text-align: center;">High Voltage Electric Shock Hazard</p> <ol style="list-style-type: none"> 1. To avoid electric shock, disconnect the cryopump from all power sources before making electrical connections between system components and before performing troubleshooting or maintenance procedures. 2. When you connect the cryopump to a power source, ensure it is a 208 VAC, Single-Phase 5 Amp source.
	<p style="text-align: center;">⚠ CAUTION</p> <p style="text-align: center;">Heavy Object</p> <p>To avoid injury when moving the cryopump, use a lifting aid and proper lifting techniques.</p>
	<p style="text-align: center;">⚠ CAUTION</p> <p style="text-align: center;">High Pressure Gas Hazard</p> <p>To avoid injury from unexpectedly propelled objects, always bleed the helium charge to atmospheric pressure before servicing or disassembling the self-sealing couplings.</p>

NOTE: To avoid loss of helium, do not modify or remove the pressure relief valves. (See *Figure 3*) Always connect and disconnect helium flex lines with the method illustrated in *Figure 1 Inset*.

Cryopump Connections

See the following numbered steps in *Figure 1*, *Figure 2*, and *Figure 3* for cryopump installation connections.

NOTE: Before mounting the cryopump to the vacuum system, ensure that a high-vacuum isolation (hi-vac) valve is installed between the cryopump and the vacuum chamber. This isolates the cryopump from the chamber during rough pumping, cooldown, and regeneration.

NOTE: Install the cryopump in any orientation. This does not affect its performance.

The number of cryopumps connected to each compressor (your installation) varies based on the cryopump models you use. Consult Technical Support for information about specific cryopump and compressor applications.

- 1 Remove flange cover.
- 2 Clean metal seal gasket and flange.
- 3 Attach to vacuum system flange with screws or other appropriate fasteners.
- 4 Connect pressure relief valve exhaust (*Figure 3*).
- 5 Connect rough valve air supply.
- 6 Connect purge valve gas.
- 7 Attach to roughing system.
- 8 Remove dust plug and connect (tighten) helium supply line (*Figure 1 Inset*).
- 9 Remove dust cap and connect (tighten) helium return line (*Figure 1 Inset*).
- 10 Connect On-Board IS Remote keypad, if you communicate directly with cryopump.
- 11 Connect network cables. See 8040648, *On-Board IS Controller Quick Installation Instructions*.
- 12 Remove cap and connect Input Power Cable (*Figure 2*).

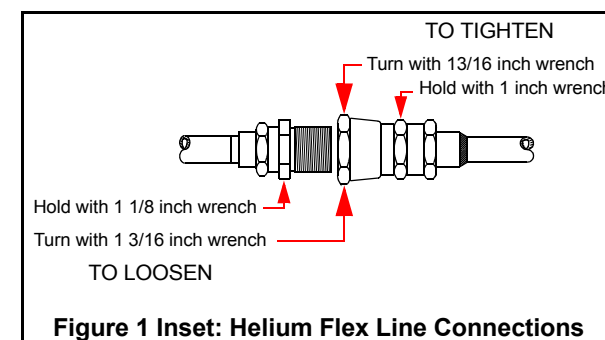
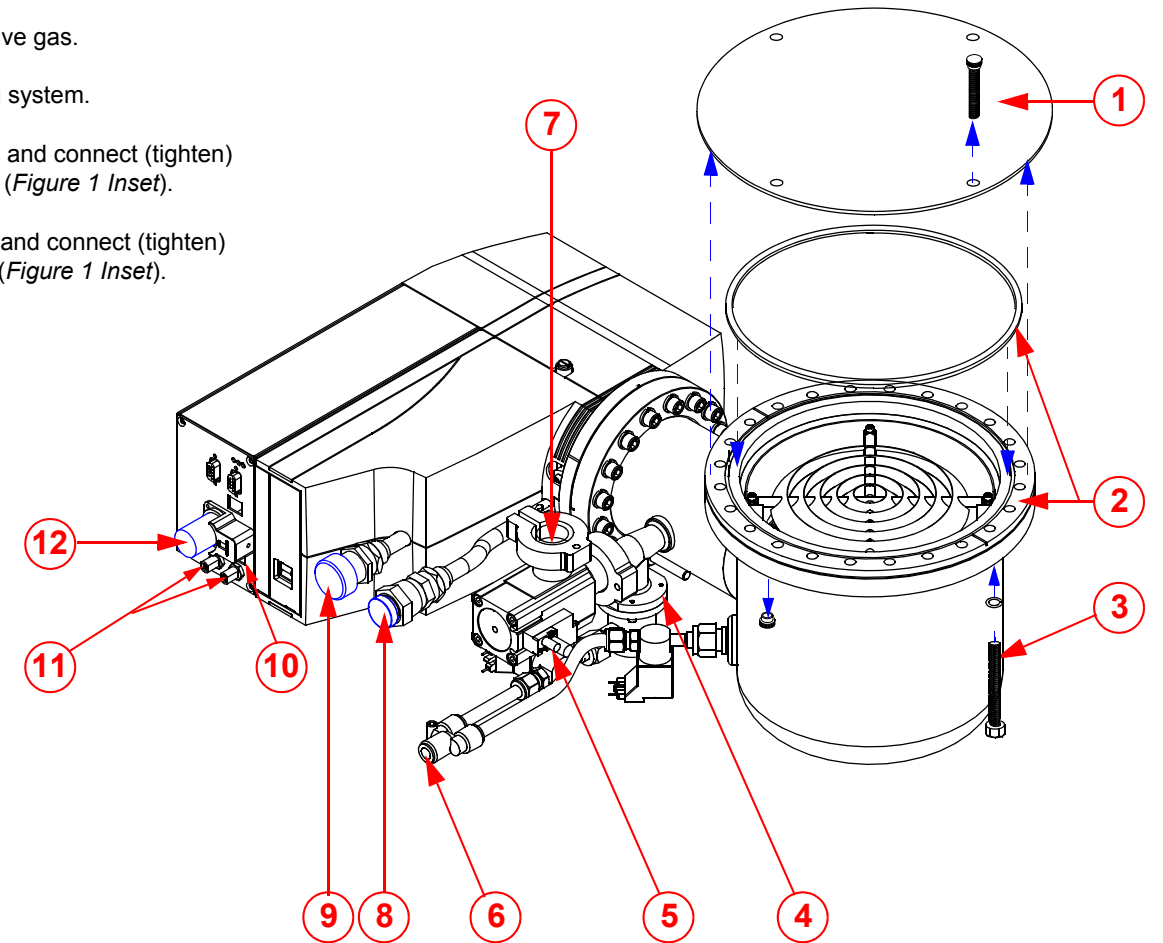

Figure 1: 8F Cryopump Basic Connections