

---

**Brooks Automation  
CTI-Cryogenics  
Network Terminal for  
300mm PVD Cryopump  
Installation and Operation Manual**

# Network Terminal for 300mm PVD Cryopump Installation and Operation Manual

---

Information provided within this document is subject to change without notice, and although believed to be accurate, Brooks Automation assumes no responsibility for any errors, omissions, or inaccuracies.

AcuLigner, AcuLine, AcuTran, AcuTrav, AeroLoader IV, AeroTrak, ARV 2000, AquaTran, Atmospheric Express, BALI 400 Indexer, BiSymmetrik, ExpressLock, FabExpress, FixLoad, FrogLeg, Gemini, Gemini Express, Gemini Express Tandem, Guardian Bare Reticle Stocker, Hercules, Hercules Express, InCooler, InLigner, InLine Express, Leapfrog, Linear eXchange, MagnaTran 7, MagnaTran 70, MagnaTran 8, MagnaTran X, Marathon, Marathon Express, Marathon Express Tandem, MicroTool, MultiTran, OneFab AMHS, OpenMTS, PASIV, PF-100, PowerPak, Reliance ATR, Reliance DFR, Reliance WCR, SENTRY, TCM, Time Optimal Trajectory, Top-Cooler, TurboStocker, TurboStocker XT, Ultrasort, VacuTran, VCD, VCE, VPE, WAVE, WAVE II, Zaris, Z-Bot, Aquatrap, Conductron, Convectron, Cool Solutions, Cryodyne, Cryogem, Cryogenerator, CryoTiger, Cryo-Torr, CTI-Cryogenics, FastRegen™, GOLDLink, Granville-Phillips, GUTS, Helix, Micro-Ion, Mini-Convectron, Mini-Ion™, On-Board, Polycold, RetroEase, RetroFast, Stabil-Ion, ThinLine™, TrueBluesm, TurboPlus, and Vacuum Assurancesm are trademarks of Brooks Automation Hardware.

All other trademarks are properties of their respective owners.

© Brooks Automation 2005, All Rights Reserved. The information included in this manual is Brooks Proprietary Information and is provided for the use of Brooks customers only and cannot be used for distribution, reproduction, or sale without the expressed written permission of Brooks Automation. This information may be incorporated into the user's documentation, however any changes made by the user to this information is the responsibility of the user.



Brooks Automation  
15 Elizabeth Drive  
Chelmsford, MA 01824  
Phone +1 (978) 262-2400  
Fax +1 (978) 262-2500  
For emergencies, contact Technical Support +1 (978) 262-2900  
[www.brooks.com](http://www.brooks.com)

September 21, 2007    Revision 0    part number 8040742, Per ECO # 18005; Alison Dann

This manual is available in the following formats: CD, Paper.

This manual is available in the following languages: English.

This technology is subject to United States export Administration Regulations and authorized to the destination only; diversion contrary to U.S. law is prohibited.

Printed in the U.S.A.

---

# Contents

---

## Introduction

General.....	1-2
Specifications .....	1-4
Front Panel Component Description .....	1-6
Rear Panel Component Description .....	1-8

## Safety

Introduction .....	2-2
Signal Word Descriptions.....	2-3
Safety Shape Descriptions.....	2-4
References .....	2-4

## Inspection and Installation

Inspection of Shipping Carton.....	3-2
Network Configurations.....	3-3
Network Terminal Installation .....	3-5
Communication Cable Connections .....	3-6
Power Cable Connections for 48 VDC .....	3-7

## Operation

Program a Cryopump Address .....	4-2
About Rough Maps .....	4-3

Create a Rough Map ..... 4-5

Set Password Protection ..... 4-6

Lock or Unlock Group Regeneration ..... 4-7

Change the Cryopumps on a Rough Map ..... 4-8

About Regeneration Groups ..... 4-9

Create a Regeneration Group ..... 4-10

Start a Group Regeneration ..... 4-11

About the RS-232 Communication Ports ..... 4-12

Set the RS-232 Port Baud Rates: ..... 4-13

## Troubleshooting

If You Cannot Start A Group FastRegen Cycle ..... 5-2

If You Cannot Communicate With A Pump ..... 5-3

Network Terminal Failure Messages ..... 5-4

## Appendices

Appendix A: Customer Support Information ..... 6-2

Appendix B: RS-232 Interface Protocol Format ..... 6-3

## Figures

---

1-1	Network Terminal Panel Views (48 VDC Configuration) . . . . .	1-3
1-2	Network Terminal Dimensions (48 VDC Configuration) . . . . .	1-5
1-3	Network Terminal Keypad/Display . . . . .	1-6
1-4	Network Terminal Rear Panel Components (48 VDC Configuration) . . .	1-8
3-1	Typical Network Terminal Installation (48 VDC Configuration). . . . .	3-4
3-2	48 VDC Power Cable Pin Assignments . . . . .	3-7
4-1	Network Terminal Keypad/Display . . . . .	4-2
4-2	Rough Map Example . . . . .	4-4
6-1	RS-232 Cable Connections . . . . .	6-3

*This Page Intentionally Left Blank*

## Tables

---

1-1	Network Terminal Specifications .....	1-4
2-1	Safety Signal Words .....	2-3
2-2	Safety Shapes .....	2-4
3-1	Shipping Carton Contents (48 VDC Configuration) .....	3-2
3-2	Power Cable Pin Assignments .....	3-7
5-1	Network Terminal Failure Messages .....	5-4
6-1	Result Codes .....	6-9
6-2	Network Terminal RS-232 Commands .....	6-10

*This Page Intentionally Left Blank*

# 1

# Introduction

---

## Overview

This Introduction provides a brief overview of this Brooks Automation Product.

## Chapter Contents

General.....	1-2
Specifications .....	1-4
Front Panel Component Description .....	1-6
Alphanumeric Display .....	1-6
Horizontal Scroll Display Keys .....	1-6
Vertical Scroll Display Keys (Last, Next) .....	1-6
Clear Display Key .....	1-6
Numeric Keypad .....	1-7
Enter Command Key .....	1-7
Function Keys.....	1-7
Service RS-232 Port .....	1-7
Rear Panel Component Description .....	1-8
Power In .....	1-8
ON/OFF Switch.....	1-8
Pumps 00 - 09 Port.....	1-8
Pumps 10 - 19 Port.....	1-8
Host RS-232 Port .....	1-9
AUX RS-232 Port .....	1-9
Ground Stud .....	1-9
LED Indicator .....	1-9

## General

The Network Terminal is used in multiple cryopump installations to provide control of up to 20 cryopumps from a single point. The Network Terminal has a built-in keypad and display that allows monitoring and control of any cryopump on the network.

The Network Terminal can be connected to a host computer through the Host RS-232 serial port so that the host can also address any cryopump on the network. The Network Terminal also coordinates the use of rough valves in a specified group of cryopumps. This prevents cross contamination of the cryopumps through the rough lines during regeneration. Cryopumps can be mapped together and the rough valves in that map are controlled through a token pass protocol. The Network Terminal allows you to initiate regenerations simultaneously to two or more cryopumps. See [Operation on page 4-1](#) for more information.

**NOTE:** *All personnel with installation and operation responsibilities should become familiar with the contents of this manual to ensure high quality, safe, and reliable Network Terminal performance.*

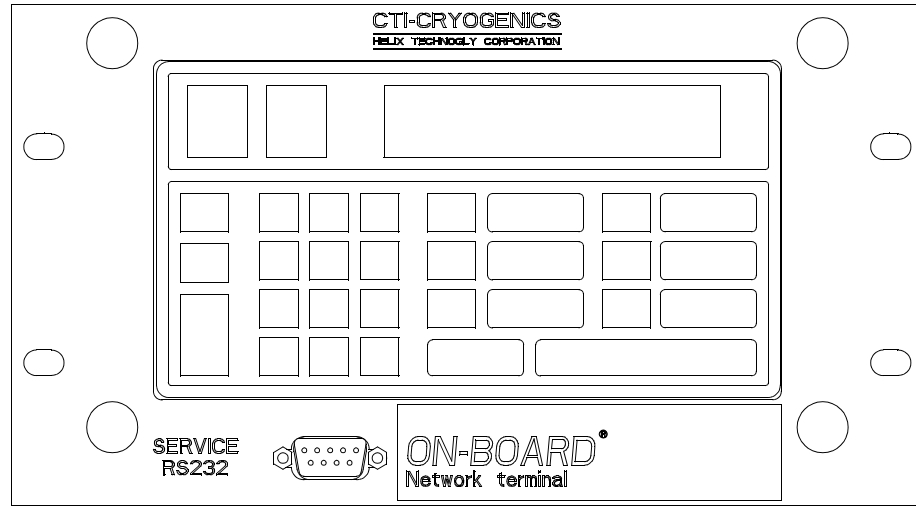

Front Panel

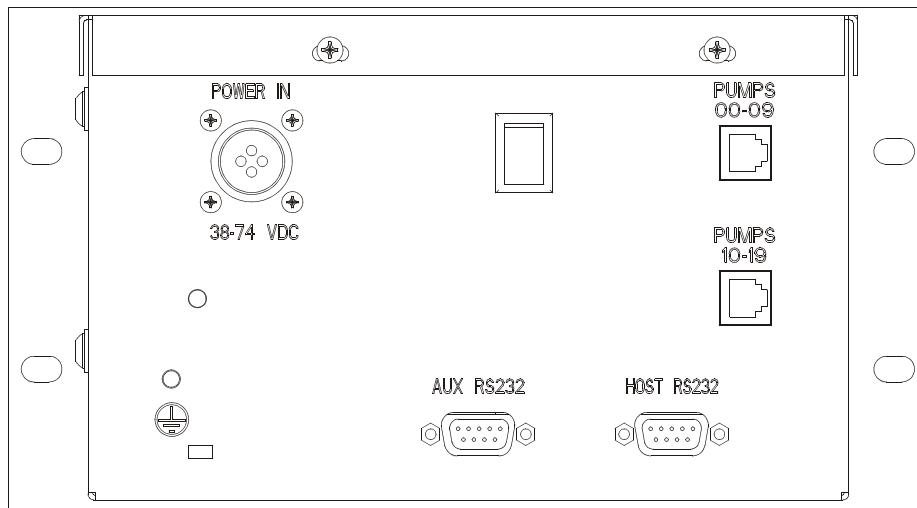

Rear Panel

Figure 1-1: Network Terminal Panel Views (48 VDC Configuration)

## Specifications

See the following table for specifications.

*Table 1-1: Network Terminal Specifications*

<b>Parameter</b>	<b>Value</b>
Weight	11 lbs. (5.5Kg)
Electrical Input (48 VDC)	38 - 72 VDC 48 VDC Nominal 1/4 amp maximum
Ambient Temperature	50° F - 100° F (10° C - 38° C)
Communication Interface	Host, Service, Auxiliary: RS-232, 9 pin D connector
Communication Inter- face Baud Rates	Host: 2400, 9600, 19200, and 38400 Service: 2400, 9600, and 19200 Auxiliary: 2400, 9600, and 19200
Software Interface	Standard protocol using cryopump ID number. See <a href="#">Appendix B: RS-232 Interface Protocol Format on page 6-3</a> for more information.

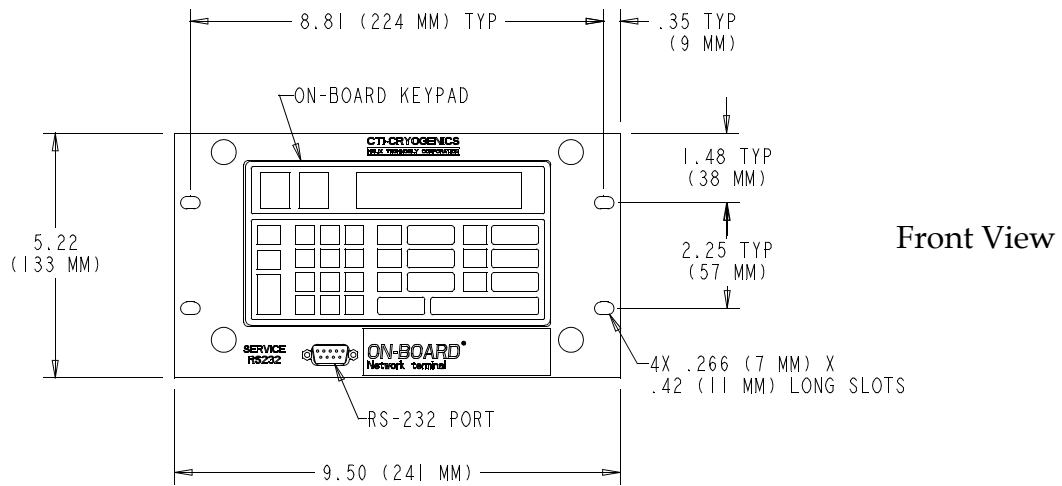
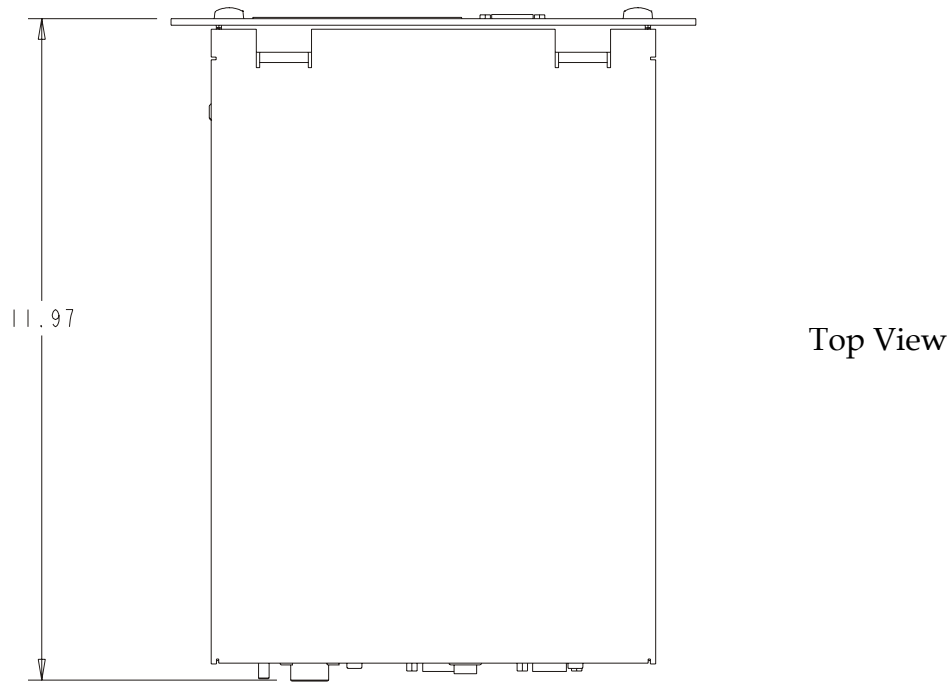

Figure 1-2: Network Terminal Dimensions (48 VDC Configuration)

**NOTE:** Ensure 3 inches (76mm) in front of the Network Terminal is clear for all cables.

## Front Panel Component Description

The keypad/display shown in the following figure, provides an interface to the Network Terminal to program and operate all cryopump functions. This section explains the purpose of each keypad/display function.

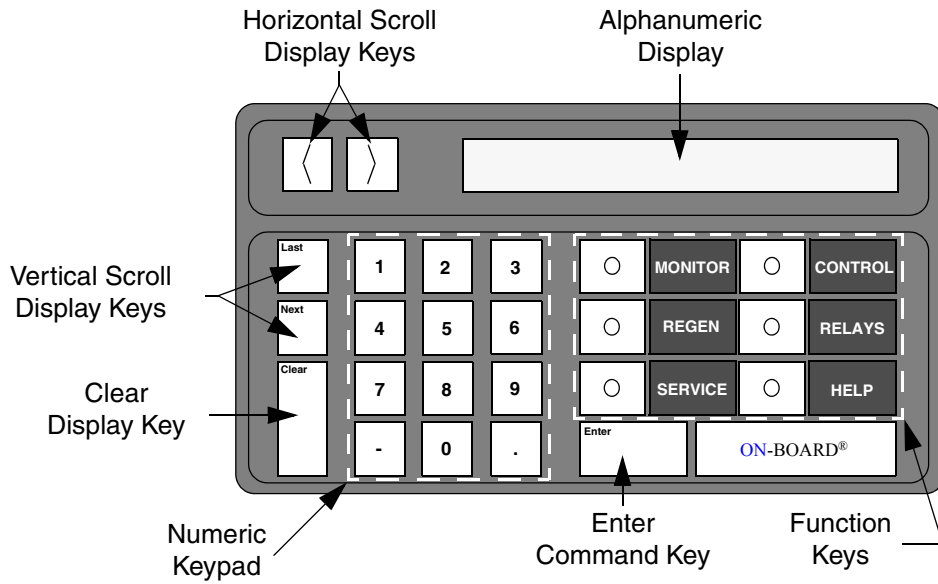

Figure 1-3: Network Terminal Keypad/Display

### Alphanumeric Display

Displays up to 16 alphanumeric characters of data entry. View messages longer than 16 characters by pressing the horizontal scroll display keys.

### Horizontal Scroll Display Keys

Move the message to the left or right on the display, if a message is longer than 16 characters.

### Vertical Scroll Display Keys (Last, Next)

Displays the previous or proceeding messages.

### Clear Display Key

Removes displayed information during programming or device selection.

**NOTE:** *Press the Clear key before the Enter key to remove information.*

### **Numeric Keypad**

Types numeric values for programming and operation.

### **Enter Command Key**

Accepts numeric information entered with the numeric keypad.

### **Function Keys**

Selects a software function.

### **Service RS-232 Port**

Connects the RS-232 port to a computer for communication. The port supports baud rates of 2400, 9600, and 19200.

## Rear Panel Component Description

The following describes the rear panel components of the Network Terminal as shown in the following figure.

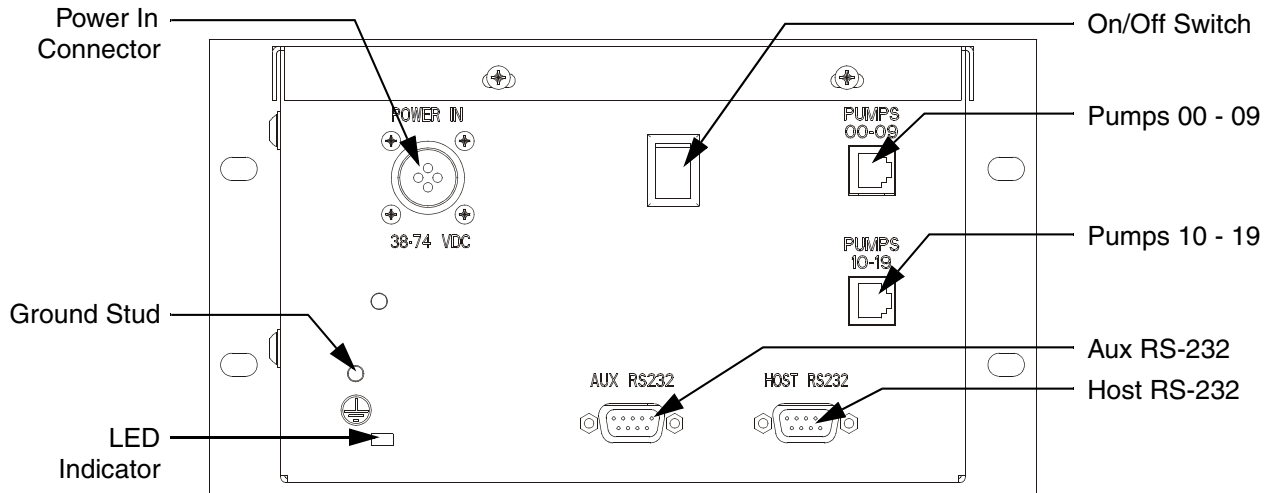

Figure 1-4: Network Terminal Rear Panel Components (48 VDC Configuration)

### Power In

Accepts an AMP #206060-1 mating connector that allows 38 - 72 VDC (48 VDC nominal) for the Network Terminal.

### ON/OFF Switch

Turns power ON or OFF. See to [Network Terminal Installation on page 3-5](#) for more information.

### Pumps 00 - 09 Port

Connects cryopumps 00 through 09 to the Network Terminal.

### Pumps 10 - 19 Port

Connects cryopumps 10 through 19 to the Network Terminal.

### Host RS-232 Port

Connect a host computer to the Network Terminal. The port supports baud rates of 2400, 9600, 19200, and 38400.

**NOTE:** *The Host RS-232 cables must be fully shielded through to the connector shell. Use cable part number 8132157 or equivalent.*

### AUX RS-232 Port

Connects a PC to control the Network. The port supports baud rates of 2400, 9600, and 19200.

**NOTE:** *The AUX RS-232 cables must be fully shielded through to the connector shell. Use cable part number 8132157 or equivalent.*

### Ground Stud

Provides a ground for Electromagnetic Interference (EMI). It is not a protective ground.

### LED Indicator

Indicates when power is ON.

*This Page Intentionally Left Blank*

# 2

# Safety

---

## Overview

This section describes safety conventions for the Brooks Automation Product. All personnel involved in the operation or maintenance of the product must be familiar with the safety precautions outlined in this section.

**NOTE:** *These safety recommendations are basic guidelines. If the facility where the Product is installed has additional safety guidelines they should be followed as well, along with the applicable national and international safety codes.*

## Chapter Contents

Introduction .....	2-2
Signal Word Descriptions.....	2-3
Safety Shape Descriptions.....	2-4
References .....	2-4

## Introduction

Follow all safety precautions during installation, normal operation, and when servicing CTI-Cryogenics products.



This chapter explains the safety conventions used throughout this manual. CTI-Cryogenics uses a specific format for cautions and warnings, which includes standard signal words and safety shapes.

See also the *Customer Support* appendix or call your local Customer Support Center for assistance.

## Signal Word Descriptions

All cautions and warnings contain signal words, which call attention to safety messages and designate the degree of hazard seriousness. The following table shows the signal words and their meanings that may be used in this document.



Table 2-1: Safety Signal Words

Term	Example	Definition
CAUTION		A signal word that indicates a situation or unsafe practice, which if not avoided may result in <b>equipment damage</b> . A CAUTION is highlighted in yellow.
CAUTION		A signal word accompanied by a safety shape that indicates a potentially hazardous situation or unsafe practice. If not avoided, the action may result in <b>minor or moderate personal injury or equipment damage</b> . A CAUTION is highlighted in yellow.
WARNING		A signal word accompanied by a safety shape that indicates indicates a potentially hazardous situation. If not avoided, the action may result in <b>serious injury or death</b> . A WARNING is highlighted in orange.

## Safety Shape Descriptions

All cautions and warnings contain safety shapes, which have specific safety meanings. The following table shows some of the safety shapes used in this document and their meanings.

Table 2-2: Safety Shapes

Example	Term	Shape Definition
	General Warning	Indicates a general hazard. Details about this hazard appear in the safety notice explanation.
	High Voltage	Indicates a high voltage hazard.
	Hot Surface	Indicates a surface is hot enough to cause discomfort or a burn.

## References

For more information about safety standards, see the following documents:

- ISO 7010: 2003(E), Graphic symbols - Safety colours and safety signs - Safety signs used in workplaces and public areas
- ISO 3864-1: 2002(E), Graphic symbols - Safety colours and safety signs - Part 1: Design principles for safety signs in workplaces and public areas

# 3 Inspection and Installation

---

## Overview

This chapter provides inspection and installation procedures for this Brooks Automation Product.

## Chapter Contents

Inspection of Shipping Carton .....	3-2
Network Configurations .....	3-3
Network Terminal Installation .....	3-5
Communication Cable Connections .....	3-6
Power Cable Connections for 48 VDC .....	3-7

## Inspection of Shipping Carton

On receipt, inspect the Network Terminal for evidence of damage. Report any damage to the shipping company at once. Retain the shipping cartons for storage or return shipment.

Examine the overall exterior, keypad, electrical connectors, ON/OFF switch, and the power cable for damage.

The Network Terminal is shipped with the components shown in the following table.

*Table 3-1: Shipping Carton Contents (48 VDC Configuration)*

<b>Description</b>	<b>Quantity</b>
Network Terminal	1
Installation and Operation Manual	1
Terminator	2

## Network Configurations

Connect as many as 20 cryopumps to the Network Terminal. The cryopumps are networked together using network cables. Before connecting the cryopumps together, set the addresses on each cryopump so that each cryopump has its own number from 00-09.

The network cables are run from cryopump to cryopump, as shown in [Figure 3-1 on page 3-4](#). The first connection is made to the *Pumps 00-09* connector for cryopumps 00-09 on the rear panel of the Network Terminal. The cryopumps need not be connected in sequential numerical order. Cryopumps numbered 10-19 must be connected to the *Pumps 10-19* connector. Set the address switches on the cryopump modules to 00-09 respectively, but are recognized by the Network Terminal as cryopumps 10-19.

Do not exceed a total network chain of 1,000 feet. This means that the cable distance from the Network Terminal to the last module could be connected with three 300 foot cables for a total network chain of 900 feet.

Use terminators to ensure proper data communication between the Cryopump Modules and the Network Terminal. Attach a terminator to the last module on the network chain, connected to the unused network connector as shown in [Figure 3-2 on page 3-7](#). Two terminators are supplied with the unit so that a terminator may be placed at the end of each of the two network chains.

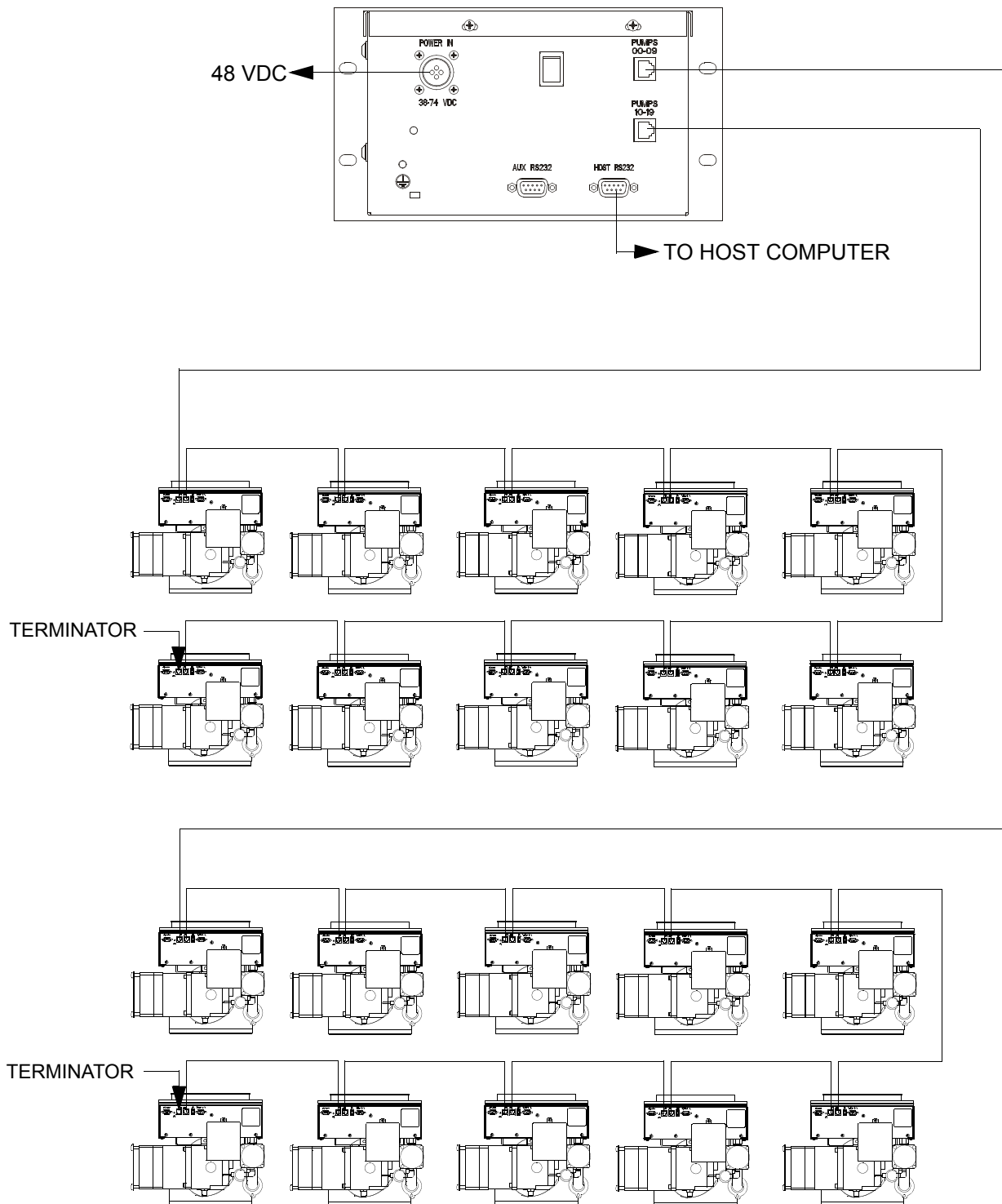

Figure 3-1: Typical Network Terminal Installation (48 VDC Configuration)

## Network Terminal Installation

1. Install the Network Terminal into the electronics rack with four mounting screws.

**NOTE:** *The bonding stud on the rear panel of the Network Terminal is intended for applications where Electromagnetic Interference (EMI) may be a problem. It is not to be used as a protective ground. Attach a ground using accepted EMI grounding practices.*

2. If desired, connect an EMI ground conductor to the ground stud.
3. Connect the opposite end of the power cable to the power source.

Proceed with the connection in the next section.

## Communication Cable Connections

See [Figure 3-1 on page 3-4](#) throughout this procedure.

1. Connect the communications cable from the first group of 10 cryopumps to the 00 - 09 connector.
2. Connect the communications cable from the second group of 10 cryopumps to the 10 - 19 connector.

**NOTE:** *Do not route the RS-232 cables with power cables and other equipment that may generate excessive EMI conditions.*

3. If required, connect the RS-232 cable from a host computer to the HOST RS-232 connector.
4. If required, connect additional Network Terminals (48 VDC), or NetLinks to the Network Connectors. Set the Network Terminal address switch to the correct address.
5. Set the power switch on the Network Terminal rear panel to the ON position.

The Network Terminal is ready for use. See the next chapter, [Operation on page 4-1](#).

## Power Cable Connections for 48 VDC

See the following figure to connect to your power supply:

1. Remove an appropriate amount of insulation from the power cable conductors to connect to the power supply.
2. Connect the WHITE wire to the Positive (+) power supply terminal.
3. Connect the BLACK wire to the Negative (-) power supply terminal.
4. Connect the Green/Yellow wire to the Chassis Ground power supply terminal.
5. Insert the power cord connector into the POWER IN connector on the Network Terminal.

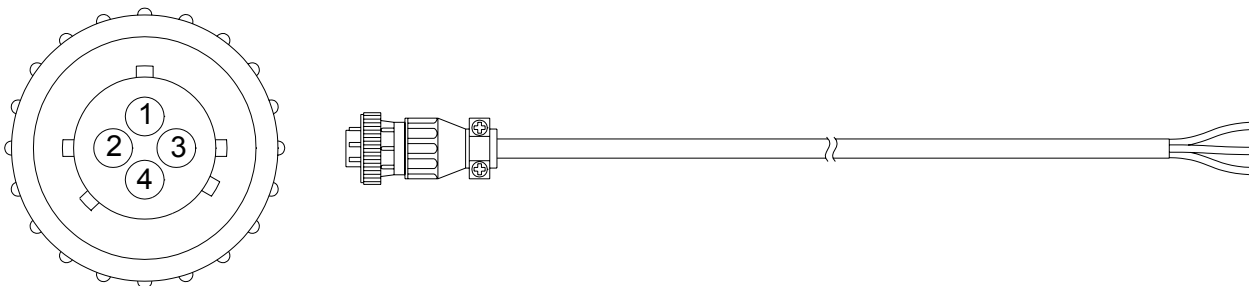

Figure 3-2: 48 VDC Power Cable Pin Assignments

Table 3-2: Power Cable Pin Assignments

Pin	Wire Color	Signal
1	Not Used	N/A
2	White	(+)
3	Green/Yellow	Ground
4	Black	(-)

Proceed to the next section for installation.

*This Page Intentionally Left Blank*

# 4

# Operation

---

## Overview

This chapter provides operation instructions for the Brooks Automation Product.

## Chapter Contents

Program a Cryopump Address .....	4-2
About Rough Maps .....	4-3
Create a Rough Map .....	4-5
Set Password Protection .....	4-6
Lock or Unlock Group Regeneration .....	4-7
Change the Cryopumps on a Rough Map .....	4-8
About Regeneration Groups .....	4-9
Create a Regeneration Group.....	4-10
Start a Group Regeneration .....	4-11
About the RS-232 Communication Ports .....	4-12
Set the RS-232 Port Baud Rates:.....	4-13

## Program a Cryopump Address

To address any cryopump on the Network:

1. Press the function key for the desired function, such as MONITOR, or REGEN.
2. Enter the two-digit number for the cryopump you want to program, such as 00, 01, or 02.

The display shows that a session with the cryopump opens as shown in the following figure.

The display advances to normal pump keypad functionality.

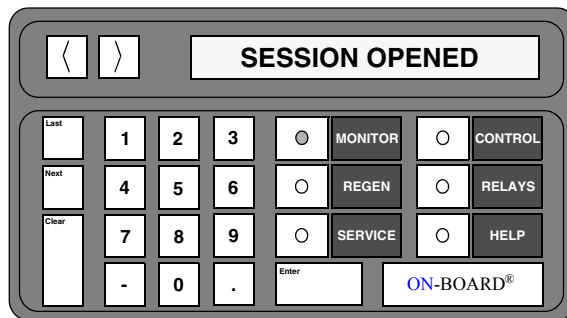

Figure 4-1: Network Terminal Keypad/Display

3. Operate the cryopumps in accordance with the operating instructions contained within the *cryopump Module Programming and Operation Instructions*, part numbers 8040509 and 8040511.
4. To change to another pump, press any function key and enter the new two-digit number.

## About Rough Maps

A rough map describes all of the cryopumps that share a rough manifold. [Figure 4-2 on page 4-4](#) shows how you may organize several rough maps.

Up to five rough maps can be set up on a multiple cryopump system through the Network Terminal.

If your system has more than one rough manifold, then you can have more than one rough map. It is possible to have up to five rough maps in a multiple cryopump system. When the cryopumps are properly mapped, the Network Terminal coordinates the use of the rough valves for both Full and FastRegen cycles.

If several cryopumps on the same manifold begin a FastRegen cycle, then they must all be started at the same time. The Network Terminal coordinates the simultaneous starting of pumps through **Regeneration Groups** as described within this section.

After a cryopump within a rough map starts FastRegen, no other cryopump in that map starts a FastRegen until the first cryopump falls 115K in cooldown. You may start a Full Regeneration individually or in groups at any time. If a FastRegen is currently in progress, then the cryopump in Full Regeneration does not rough out until the FastRegen cryopump falls below 115K in cooldown.

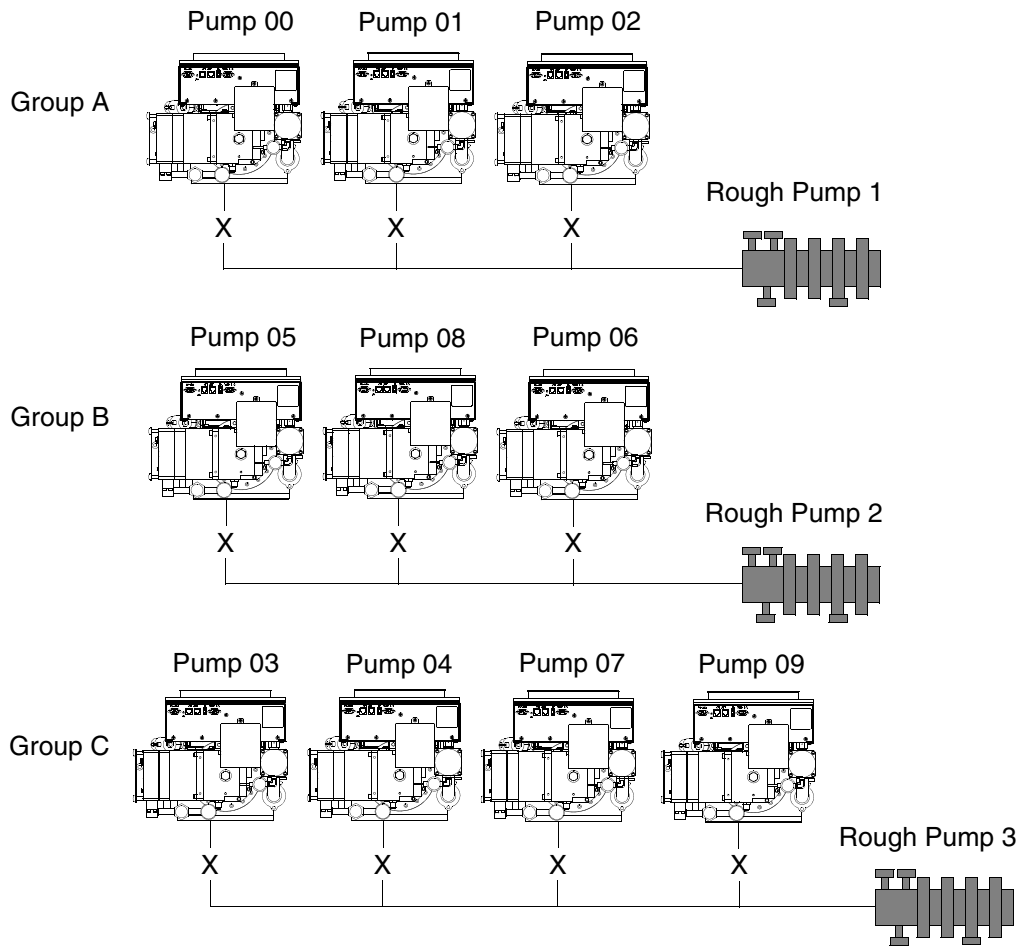

Figure 4-2: Rough Map Example

## Create a Rough Map

Use the following procedure to create a rough map as shown in [Figure 4-2 on page 4-4](#).

**NOTE:** *A rough must contain at least two cryopumps.*

1. Press **SERVICE**, then press **9 9**.  
The serial number and the software version appear on the display.
2. Press **Next**.  
*TERMINAL ID #XX* appears if you have NetLink installed.
3. Press **Next**.  
The number of cryopumps on network appears.
4. Press **Next**.  
*PASSWORD?* appears.
5. Press **Enter**, then **Next**.  
*REGEN LOCK OFF* appears.
6. Press **Next**.  
*ROUGH VALVE MAP* appears.
7. Press **Enter**.  
*MAP A* appears.
8. Press **Enter**.
9. Press **00 Enter**, **01 Enter**, **02 Enter**, **Enter**.  
*MAP A* is complete. The *MAP B* appears.
10. Press **Enter**.  
You may program more rough maps, if necessary, or return to the main display.

## Set Password Protection

1. Press the **SERVICE** key.
2. Press **9 9** to open the local service function of the Network Terminal, not a cryopump.  
The serial number and the software version appear.
3. Press **Next**.  
*TERMINAL ID #XX* appears if you have NetLink installed.
4. Press **Next** to scan the Network and to display the number of pumps on the network, up to 20.
5. Press **Next** to display a password request.
6. Type a password, press **Enter**, and then **Next**.

The password is set. You may return to the main display.

## Lock or Unlock Group Regeneration

1. Press the **SERVICE** key.
2. Press **9 9** to open the local service function of the Network Terminal, not a cryopump.  
The serial number and the software version appear.
3. Press **Next**.  
The *TERMINAL ID #XX* appears if you have NetLink installed.
4. Press **Next** to scan the Network and to display the number of pumps on the network, up to 20.
5. Press **Next** to display a password request.
6. Press **Next**.  
The *REGEN LOCK OFF* appears on the display.
7. Press **0** (unlock) so that you may continue to use the regeneration group function.  
Press **1** (lock) to disable the Group Regeneration function.

The Group Regeneration is set. You may return to the main display.

## Change the Cryopumps on a Rough Map

1. Press the **SERVICE** key.
2. Press **9 9** to open the local service function of the Network Terminal, not a cryopump.  
The serial number and the software version appear.
3. Press **Next**.  
The *TERMINAL ID #XX* appears if you have NetLink installed.
4. Press **Next** to scan the Network and to display the number of pumps on the network, up to 20.
5. Press **Next** to display a password request.
6. Press **Next**.  
The *REGEN LOCK OFF* appears on the display.
7. Press **Next**.  
The *ROUGH VALVE MAP* appears.
8. Press **Enter**.  
The *MAP A* appears.
9. Press **Enter** to clear MAP A completely and re-create it.
10. Type the 2-digit number a cryopump you want to assign to MAP A.
11. Press **Enter** to accept that cryopump number, or press **Clear** to remove it.
12. Repeat the previous two steps for all cryopumps on MAP A.
13. After you finish assigning cryopumps to MAP A, press **Enter** to save MAP A.  
*MAP B* appears on the display.

MAP A is reset. You may return to the main display or continue changing MAP B.

## About Regeneration Groups

A *Regeneration Group* is any group of cryopumps that you want to regenerate together. These cryopumps may or may not be in the same rough map.

A multiple cryopump system can have up to five Regeneration Groups. When the regeneration starts, the Network Terminal coordinates when each cryopump uses their rough pump.

There is a special requirement for FastRegen cycles. A cryopump in the FastRegen process must have use of the rough valve at specific times. If there is more than one cryopump on a rough manifold, the cryopumps must all start and run at the same time. This also means that if there is a cryopump in the process of a FastRegen cycle, then no other cryopump on that rough manifold can start a FastRegen cycle until that cryopump is finished.

For Full Rengenerations, you may start and stop them at any time, even if another pump on the same Rough Map is in Regeneration.

## Create a Regeneration Group

1. Press **REGEN 9 9**.  
*1-MULTI PUMP RGN* appears on the display.
2. Press **Next**.  
*1=GROUP SELECT* appears.
3. Press **Next**.  
*1-MULTI* appears.
4. Press **Enter** and type the 2-digit number of a cryopump you want in Group 1.
5. Press **Enter** to save that cryopump, or press **Clear** to remove it.
6. Repeat the previous two steps for all the cryopumps you want to add to Group 1. You may have up to 20 cryopumps on a Regeneration Group.
7. Press **Next** as necessary to create other Groups, and then press **Enter** to begin adding cryopumps to a Group.

Regeneration Group 1 is set. You may return to the main display.

## Start a Group Regeneration

1. Press **REGEN 9 9**.  
*1-MULTI PUMP RGN* appears on the display. 1- indicates that Group 1 is ready for regeneration.
2. Press **1** to start a Regeneration.  
*PRESS 2 OR 3 REGEN PUMPS?* appears on the display.
3. Press **2** to start a Full Regeneration.  
Press **3** to start a FastRegen.  
Press **Clear** to cancel starting all Regenerations.
4. Press **Next** to start Regeneration for a different Group number. *1=GROUP SELECT* appears on the display.
5. Press **Enter** .
6. Type the Group number to regenerate and press **Enter**.

Regeneration is set. You may return to the main display.

## About the RS-232 Communication Ports

The Network Terminal has three RS-232 ports, each of which provides access to the Network Terminal or pump information and control. All three of the ports can be used simultaneously.

The ports are named so that they can be identified when setting the baud rate for that port. Also, the names can indicate a relative usage for each of the ports. For example, the HOST RS-232 port should typically be used for communications to the system controller so that when installed, you will know that port is constantly being used and should not be disconnected.

The AUXILIARY port and the SERVICE port could be used for programs such as On-Board Central Control. The front SERVICE port provides access to a port even when the Network Terminal is installed in a rack.

Each of the three RS-232 ports can be configured to have the same or different baud rates. The allowable rates are 2400, 9600, 19200 and 38400 for the Host port and 2400, 9600, and 19200 for the Service and Auxiliary ports. The baud rate can only be set from within the *SERVICE 9 9* function of the Network Terminal and cannot be set through an RS-232 command.

### Set the RS-232 Port Baud Rates:

1. Press the **SERVICE** key.
2. Press **9 9** to open the local service function of the Network Terminal, not a cryopump.  
The serial number and the software version appear.
3. Continue pressing **Next** until *9600 HOST BAUD* appears.
4. Type the following to choose a baud rate:  
**0** for 2400  
**1** for 9600  
**2** for 19200  
**3** for 38400
5. Repeat the previous two steps for *SERVICE BAUD* and *AUX BAUD*.

The baud rate is set. You may return to the main display.

*This Page Intentionally Left Blank*

# 5

# Troubleshooting

---

## Overview

This chapter provides troubleshooting information for this Brooks Automation Product.

## Chapter Contents

If You Cannot Start A Group FastRegen Cycle .....	5-2
If You Cannot Communicate With A Pump .....	5-3
Network Terminal Failure Messages .....	5-4

## If You Cannot Start A Group FastRegen Cycle

If you attempt to start a Group FastRegen cycle and *GROUP REGEN ERR* is displayed on the Network Terminal keypad/display, it means that the pumps were not started into regeneration for one of the following reasons:

1. One or more of the pumps in the group is too warm (above 50K) to initiate FastRegen cycle.
2. One or more of the pumps in the group is not detected as being present by the Network Terminal.

## If You Cannot Communicate With A Pump

Perform the following steps if the Network Terminal does not seem to communicate with a pump:

1. Check the pump address of the pump that you cannot communicate with and make sure it has a unique address compared with the other pumps within the system.
2. Make sure that a terminator has been installed in the network port on the last cryopump within each group (00-09 and 10-19).
3. Make sure that power is available to the pumps. Make sure the LED on the cryopump module panel is illuminated.
4. Make sure that all network cables are connected properly.

## Network Terminal Failure Messages

*Table 5-1: Network Terminal Failure Messages*

<b>Message</b>	<b>Possible Problem</b>
Session Lost	Communication was lost to that pump. Line break or noise.
Session Failed	A session was attempting to open and there was a line break or noise.
NetLink Failure	Network Terminal was at a pump but not in session (Monitor PUMP #06) and there was a line break or noise.

# 6

# Appendices

---

## Overview

The following appendices are included to provide the user with a single location for specific information related to the Brooks Automation Product.

## Contents

[Appendix A: Customer Support Information . . . . .](#) 6-2  
[Appendix B: RS-232 Interface Protocol Format . . . . .](#) 6-3

## Appendix A: Customer Support Information

### Customer Support Center Locations

To locate a Customer Support Center near you, please visit our website [www.brooks.com](http://www.brooks.com) on the world wide web and select *CONTACT* on the home page.

### Guaranteed Up-Time Support (GUTS®)

For 24-hour, 7-day per week Guaranteed Up-Time Support (GUTS) dial:

**1 800-367-4887** - Inside the United States of America

**+1 508-337-5599** - Outside the United States of America

### Product Information

Please have the following information available when calling so that we may assist you:

- Product Part Number
- Product Serial Number
- Product Application
- Specific Problem Area
- Hours of Operation
- Equipment Type
- Vacuum System Brand/Model/Date of Manufacture

### E-mail

For your convenience, you may also e-mail us at:

[techsupport@brooks.com](mailto:techsupport@brooks.com)

## Appendix B: RS-232 Interface Protocol Format

### RS-232 Computer Connections

[Caution: The RS-232 cable should not be routed with power cables and other equipment which may generate excessive EMI conditions.]

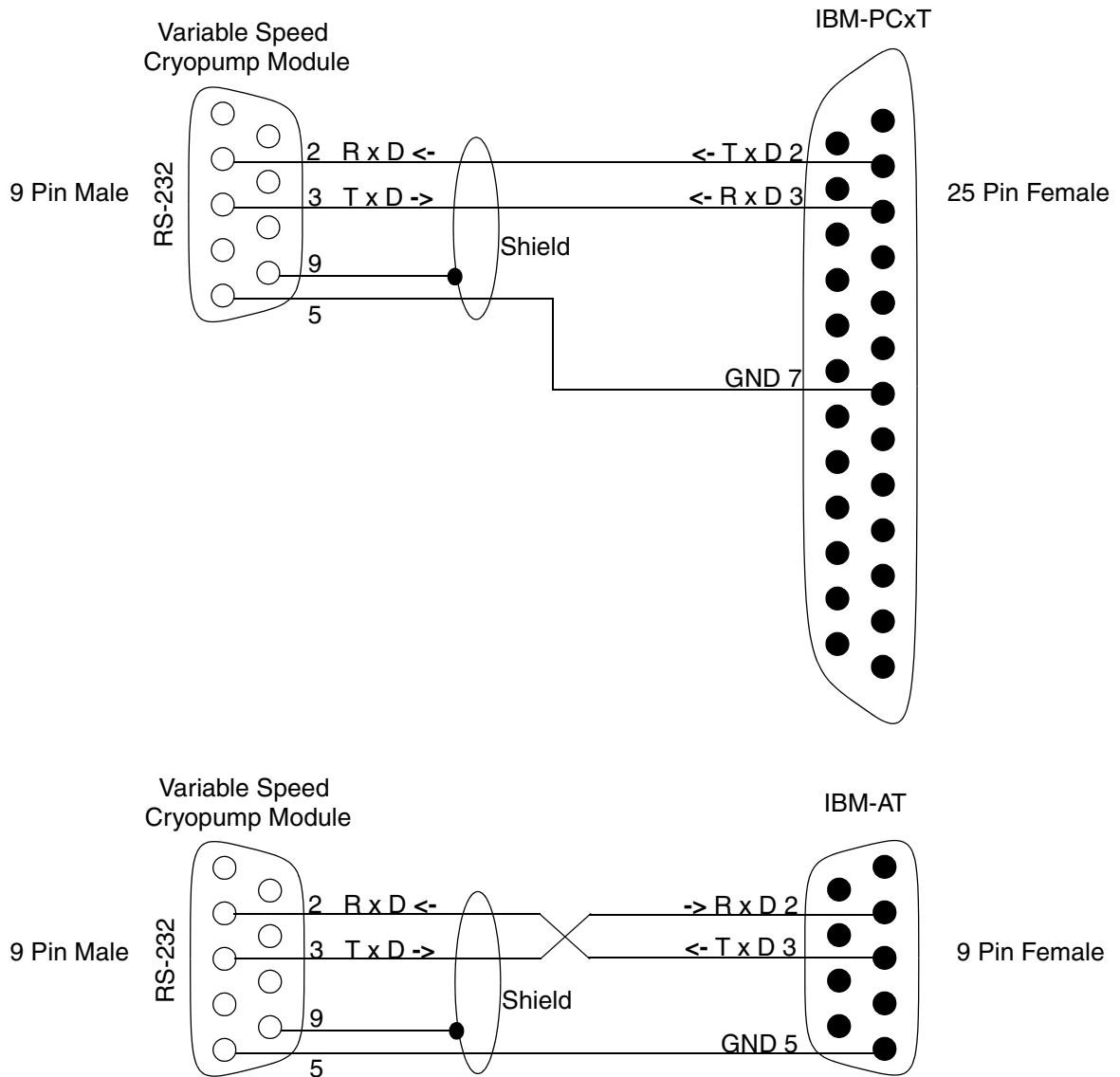

Figure 6-1: RS-232 Cable Connections

**NOTE:** Use metal case type connectors. Do not exceed 40 foot cable lengths.

## Introduction

The format of RS-232 messages between a computer device (the HOST) and the Network Terminal (slave) is the same for both directions of message flow (HOST transmitted or slave transmitted). Each message consists of a series of ASCII characters transmitted via a standard RS-232 asynchronous framing convention of one (1) start bit, seven (7) data bits, a parity bit generated for even parity, and one (1) stop bit; at a transmission rate of 2400, 9600, 14200, and 38400 baud.

The message packet is composed of a starting flag character (the \$ character, hex 24), followed by a P and the pump address (example P00=PUMP #0, P01=PUMP #1), when talking to a pump (N when talking to a Network Terminal), followed by a message dependent data field, followed by a message checksum character, terminated by an ASCII carriage return code (hex 0D). The pump address is set by means of a switch on the cryopump Module. The starting flag character serves the unique purpose of synchronizing the receiver to the transmitter, by signaling the start of the message packet. This '\$' code is not contained in the set of characters used to construct the data field or the checksum character, and therefore establishes a fixed reference point to sync up data flow. Whenever either receiver (HOST or slave) receives a '\$' character, all history and status of previous partial packet data (if any) is aborted and lost, and a packet message is started anew.

The data field consists of from one (1) to a maximum of fourteen (14) ASCII characters, the meaning of which is defined in the Pump Command List for commands and responses. All characters with the exception of '\$' and Carriage-Return (0D hex) may be employed in the data field, if suitable.

The message checksum character is employed to guard against garbled or incorrect messages being received and acted upon, causing undesirable or damaging results. Only messages which are conveyed accurately and intact from the master to slave (or visa versa) are accepted and acted upon. The checksum character which follows the data field is computed by a modified binary sum technique (described later) over the characters composing the data field. The transmitting unit generates this sum based on the characters it used to produce the data field, and appends it after the field just prior to the CR code terminator. The receiving unit performs the same checksum algorithm on all characters which it receives between the '\$' character and the character just prior to the CR terminator (non-inclusive). If this sum matches the final character preceding the CR terminator, then the message is validated and processed by the receiver. If not, then an error has occurred and the action taken depends on whether the receiver is the HOST or slave unit. The checksum algorithm generates a character between ASCII '0' and 'o' (30 hex to 6F hex) inclusive.

## Checksum Algorithm

Perform the 8 bit (modulo 256) sum of all the ASCII characters sent in the data field (with the most significant bit cleared to 0, ignore parity). This is performed for one to fourteen character code bytes. Fold the resulting eight bit sum into six bits by exclusive *oring* the two MSBs of the sum (D7, D6) with the two LSBs (D1, D0) of the sum such that the new D1 is the old D1 XOR D7 and the new D0 is the old D0 XOR D6. The resulting lower six bits (D5 - D0) are then masked off, producing a code range of from 00 to 3F hex. This is then added to the ASCII code for '0' (30 hex), generating the final printable checksum character in the range of 30 hex to 6F hex

('0' - 'o').

Message traffic is always originated by the HOST unit. This message is referred to as a command or query. Commands cause specific actions to occur in the cryopump Module. Queries request that the cryopump Module reply with status or other parametric information. The cryopump Module responds to all such correctly received messages with a response message. The pairing of these command-response or query-response message sets defines a transaction or exchange. If a faulty message is received by the cryopump Module (due to improper production in the host, or transmission media failure), the message is discarded and no response is sent back to the host as a reply. The host must be able to detect that either no response or an invalid response was received from the slave (through time-out and checksum detection), and if desired, repeat the message to the slave in an attempt to secure a valid transaction.

All communications between a host computer and the Network Terminal will occur within this message transaction framework. Software operating on the host computer must generate and interpret the message response pairs to properly execute and control remote operation and data-logging of the cryopump Module. Software within the cryopump Module interprets these valid messages and returns appropriate replies, as documented in the cryopump RS-232 command list. Error code messages may be returned by the cryopump Module if a valid message packet is received but the data field contents are not correct and cannot be interpreted. This is not a communications error, but a software error. Invalid commands, improper parameter ranges, or requests to perform operations which are disallowed for some reasons all result in an error message reply.

There are five categories of error messages. Each of the first four categories has two possible messages. The first is an error under normal conditions. The second is an error message that also signals a recent power loss. If a power loss signal is received, this flag can be reset by using the S command.

1. The normal reply for an understandable and executable message is A. If this inquiry is the first since a power failure, the message is B.

2. If a command is sent that cannot be executed under any conditions, the error message is E. If this inquiry is the first since a power failure, the message is F.
3. If a command is sent that cannot be executed except under certain conditions, due to interlocks, the return message is G. If this inquiry is the first since a power failure, the message is H.
4. If a proper command is sent but cannot be acted upon because another serial port has locked out access to all other serial ports, the response is I. If this inquiry is the first since a power failure, the response is J.
5. A fifth category for error messages consists of errors associated with the Network Terminal's inability to find a pump on the network. A response of Z (typically a "\$ZBCOMFAIL message) indicates that the Network Terminal could not address a pump on the network, most likely due to an incorrect address or powered down pump.

**NOTE:** *The previous error messages and the result codes shown in [Result Codes on page 6-9](#), see both the Network Terminal and pump error messages. The "B", "F" and "H" responses to a host from a pump may never be seen since they will be cleared by the Network Terminal. If you wish to have your system controller recognize a power failure signal which is recorded in the pump, you should use the lower case t command as described in the RS-232 command list of the appropriate cryopump manual.*

The following is an example of a typical exchange:

Host Sends query to get back cryopump Module Version Information for Pump #1

	Flag	Pump Address	Data Field	Checksum	Terminator
ASCII	[\$]	[P] [0] [1]	[@]	[b]	[CR]
Hex	[24]	[50] [30] [31]	[40]	[62]	[0D]

Checksum of Pump Address and Data Field

Bits 76543210

Sum of

50 01010000

30 00110000

31 00110001

40 01000000

Equals 11110001 or Hex F1

Bits 7 & 6 aligned for

XOR 00000011

XOR result 11110010

Mask D5, D0 00110010

Addend '0' 00110000

Final Chk 01100010 Hex 62, ASCII 'b'

Slave sends reply of AP A2.01, meaning no error, Pump version A2.01.

	Flag	Data Field	Checksum	Terminator
ASCII	[\$]	[A] [P] [] [A] [2] [.] [0] [1]	[a]	[CR]
Hex	[24]	[41] [50] [20] [41] [32] [2E] [30] [31]	[61]	[0D]

Checksum of hex data field:

Bits 76543210

Sum of

41 01000001

50 01010000

20 00100000

41 01000001

32 00110010

2E 00101110

30 00110000

31 00110001

Equals 10110011 or hex B3 modulo 256.

Bits 7 & 6 aligned for

XOR 00000010

XOR result 10110001 or B1.

Mask D5, D0 00110001

Addend '0' 00110000

Final Chk 01100001 Hex 61, ASCII 'a'

## Result Codes

All of the RS-232 ports support hardware and software busy signals. Use pin 8 of the RS-232 Connector for clear to send (CTS) hardware busy.

Use hardware and XON and XOFF for software.

*Table 6-1: Result Codes*

Letter	Description
A	Command understood, resultant reply (if any) follows, no power failure or reset occurrences since last acknowledgment.
B	Command understood, resultant reply (if any) follows, also a reset event has occurred which has not been acknowledged. This may require messages to synchronize the state information between boxes.
E	Invalid command token or invalid data argument for the given command. No power failure or reset occurrences since last acknowledgment.
F	Invalid command token or invalid data argument for the given command, also a reset event has occurred which has not been acknowledged.
G	Proper command which cannot be acted upon currently for some reason which may be temporary or correctable. No power failure or reset occurrences since last acknowledgment.
H	Proper command which cannot be acted upon currently for some reason which may be temporary or correctable, also a reset event has occurred which has not been acknowledged.
I	Proper command sent but cannot be acted upon because another serial port has locked out access to all other serial ports. No power failure or reset occurrences since last acknowledgment.
J	Proper command sent but cannot be acted upon because another serial port has locked out access to all other serial ports. Also a reset event has occurred which has not been acknowledged.

Table 6-2: Network Terminal RS-232 Commands

Command	Parameter	Description
?	None	Acknowledges that host computer is aware of a power reset state at the multiplexor, resetting the internal state which causes the 'A' reply to be returned as a 'B'. This is sent as an initializes the host to be in sync with the Network controller, so that subsequent resets are then detectable when the controller returns 'B' for the normal 'A' status reply.
@	None	Returns an identifier string indicating module type and software revision level. Format is:"M AN.M" where the M indicates a multiplexor type module, and the A letter reflects the option compliance type N.M is a decimal radix version number (2.0, 2.1, - 9.9 etc.). Major revisions may increment N to the next ASCII number value. Any change will increase the M minor number to the next level.
A	?	If ? as argument then returns the eleven character serial number for the multiplexor unit.

Table 6-2: Network Terminal RS-232 Commands

Command	Parameter	Description																																										
B	None	<p>Returns a numeric code that identifies which pump modules are currently active on the network. When this command is sent, the network multiplexor sends out a polling request to all pumps. This takes a little bit of time. Once completed, the pumps found to be active are configured according to the rough valve cooperation groupings already defined in the Network controller. The returned code is a number from 0 to 1,048,575 decimal, comprised of the sum of binary bit weights for each of the twenty possible pumps according to the following information:</p> <table data-bbox="657 766 917 1543"> <thead> <tr> <th>PUMP #</th> <th>Weight</th> </tr> </thead> <tbody> <tr><td>0</td><td>1</td></tr> <tr><td>1</td><td>2</td></tr> <tr><td>2</td><td>4</td></tr> <tr><td>3</td><td>8</td></tr> <tr><td>4</td><td>16</td></tr> <tr><td>5</td><td>32</td></tr> <tr><td>6</td><td>64</td></tr> <tr><td>7</td><td>128</td></tr> <tr><td>8</td><td>256</td></tr> <tr><td>9</td><td>512</td></tr> <tr><td>10</td><td>1024</td></tr> <tr><td>11</td><td>2048</td></tr> <tr><td>12</td><td>4096</td></tr> <tr><td>13</td><td>8192</td></tr> <tr><td>14</td><td>16384</td></tr> <tr><td>15</td><td>32768</td></tr> <tr><td>16</td><td>65536</td></tr> <tr><td>17</td><td>131072</td></tr> <tr><td>18</td><td>262144</td></tr> <tr><td>19</td><td>524288</td></tr> </tbody> </table>	PUMP #	Weight	0	1	1	2	2	4	3	8	4	16	5	32	6	64	7	128	8	256	9	512	10	1024	11	2048	12	4096	13	8192	14	16384	15	32768	16	65536	17	131072	18	262144	19	524288
PUMP #	Weight																																											
0	1																																											
1	2																																											
2	4																																											
3	8																																											
4	16																																											
5	32																																											
6	64																																											
7	128																																											
8	256																																											
9	512																																											
10	1024																																											
11	2048																																											
12	4096																																											
13	8192																																											
14	16384																																											
15	32768																																											
16	65536																																											
17	131072																																											
18	262144																																											
19	524288																																											

Table 6-2: Network Terminal RS-232 Commands

Command	Parameter	Description
B (contined)	None	For example, a code of 0 indicates no pumps responding. A code of 12 indicates pump 2 and pump 3 are responding. This notation is a compressed form of set notation. The member positions for the set are the bit positions 0 through 19. If a set has a member, the bit is true (1). If a set does not have a member, the bit is false (0). In this way, simple boolean bitwise operations (such as those available in the C language) can perform the operations of union, intersection, etc. for set membership. A number representing the set of pumps which require cooperation is the union of the five groups (A through E in Display menu) sets. This can be generated by bitwise <i>oring</i> the individual sets. The NULL set or empty set is the number 0. All of the other pump groupings or set membership functions use this notation to describe the contents of a set when read back or set.
C	[1 - 5]	Returns a numeric code that identifies which pump modules are in the selected rough valve map. The parameter 1 through 5 selects the maps 'A' through 'E' which can be reviewed and programmed through the keypad terminal when the 99 select code is entered from the Service menu. The bit weights for the set notation are the same as for the B command above.
D	[1 - 5] [0-1048575]	Accepts a numeric code that identifies which pump modules are mapped in the selected rough valve map. The parameter 1 through 5 selects the groups 'A' through 'E' which can be reviewed and programmed through the keypad of the Network Terminal when the 99 select code is entered from the Service menu. The bit weights for the set notation are the same as for the B command above. In this way thorough valve map can be remotely programmed. A logical limitation is imposed such that a cooperation set must have at least two members, and the members so defined must not be present in any of the other four (non-selected) set maps. To move a pump from one grouping to another it must first be removed from the old map before being set into a new map.

Table 6-2: Network Terminal RS-232 Commands

Command	Parameter	Description
E	None	Returns a numeric code that identifies which pump modules are assigned to one of the five cooperative sets. This membership is logically based on the programming of the five sets, and does not rely on whether the pumps are currently communicating or not. Pump modules not in this set are not required to cooperate when accessing a rough valve during automatic REGENs.
F	None	Returns a numeric code that identifies which pump modules have a need to cooperate for rough valve (which means they are in the set data returned by the E command above) have been granted the exclusive use of the rough valve for their set. Membership in this set indicates an active REGEN in process for the corresponding member pump. Other pumps which belong to the same map sets ('A' - 'E') as those currently granted rough usage will be held off from REGEN usage of the rough valve until relinquished.
G	?   0 - 32767	Command to set or query the Multiplexor Network password value. If a ? is the argument, then the current password value is returned. This value is used to open up menu access to the remote pumps using one common password. If a number 0 - 32767 is the argument, then this value becomes the new password value, with a value of 0 being no password.

Table 6-2: Network Terminal RS-232 Commands

Command	Parameter	Description												
L	None Returns Set Code 0 - 31	Query which of map sets A - E are locked out by external intelligence. Power up defaults to none. M command may acquire or grab sets which are not already in cooperative use. N command is used to free or release remote sets. They are also automatically released if the Network Terminal is not given L query at least each 5 seconds when supervision active. O command sets/clears/queries supervisor mode. Returned value is sum of remote locked set's identification weights.  <table border="0"> <tr> <td>SET ID #</td> <td>Weight</td> </tr> <tr> <td>A</td> <td>1</td> </tr> <tr> <td>B</td> <td>2</td> </tr> <tr> <td>C</td> <td>4</td> </tr> <tr> <td>D</td> <td>8</td> </tr> <tr> <td>E</td> <td>16</td> </tr> </table>	SET ID #	Weight	A	1	B	2	C	4	D	8	E	16
SET ID #	Weight													
A	1													
B	2													
C	4													
D	8													
E	16													
M	Set Code 0 - 31 Returns Set Code 0 - 31	Command to acquire sets which are not already in cooperative use. Zero or more sets can be identified to be disabled from the rough grant cycle in the Network Terminal. Those sets so identified and not already in use are added to the set or remote lock out sets and returned in the value which is the now current remote lock out set code as would be returned in the L command.												
N	Set Code 0 - 31	Command to free or release remote sets. They are also automatically released if the Network Terminal is not given L query at least each 5 seconds when supervision active. Sets which are desired to be freed are entered as elements of a set code. They are then released. No error is caused by releasing sets not currently held.												
O	?   = [0 - 1]	Command which sets/clears/queries supervisor mode. When set (=1), a periodic L command to poll the state of the remote lock out rough sets is required to maintain these sets locked out. If 5 seconds elapses with no such poll, then the sets are released to the Network Interface Terminal operation. Supervisor action may be released (the default) by using a =0 argument. A ? argument allows the current state to be examined.												

Table 6-2: Network Terminal RS-232 Commands

Command	Parameter	Description
P	None	Returns a numeric code that identifies which pump modules are assigned as a group for multi-REGEN start/stops. This matches the grouping defined using the multi-regeneration path (ID #99) of the regeneration menus. The returned code has the same meaning as in the B command.
Q	[0 - 1048575]	Accepts a numeric code that identifies which pump modules are to be grouped together for common regeneration start/stops from the display regeneration MULTI menu. The entered code has the same meaning as in the B command above.
V	?   = [0 - 1]	Query set or clear the CMOS GrpRgnLock flag used to control access to display Multi REGEN request.
W	[1-5] [0 - 1048575]	Accepts a numeric code that identifies which pump modules are grouped in the selected gang start pump grouping. The parameter 1 through 5 selects the groups '1' through '5' which can be reviewed and programmed through the keypad of the Network Terminal when the 99 select code is entered from the REGEN menu. The bit weights for the set notation are the same as for the B command. In this way, the group start can be remotely programmed. Pumps in any such group will be commanded to start either a Full regeneration or a FastRegen cycle (if FastRegen is available) by a manual keypad REGEN start or remote computer interface command to start. If a FastRegen group start is requested, it will be abandoned if any of the pumps included in the group are not capable of performing a FastRegen cycle.
X	[1 - 5]	Returns a numeric code that identifies which pump modules are grouped in the selected gang start grouping. The parameter 1 through 5 selects the groups '1' through '5' which can be reviewed and programmed through the keypad of the Network Terminal when the 99 select code is entered from the REGEN menu. The bit weights for the set notation are the same as for the B command above. Any pump can be present in any one of the groups 1-5.

Table 6-2: Network Terminal RS-232 Commands

Command	Parameter	Description								
Y	[1 - 5] [0,2,3]	Requests to abort (0) / start Full (2) / or start Fast (3) the specified group 1 - 5. All pumps which are in the grouping will be commanded to start or stop the regeneration according to the 0/2/3 parameter. The parameter 1 through 5 selects the groups '1' through '5' which can be reviewed and programmed through the keypad of the Network Terminal when the 99 select code is entered from the REGEN menu. The REGEN stop selection code of 0 will cause a stopREGEN command to be sent to all of the pumps in the selected gang-group. A REGEN start command (2 or 3) will cause all of the pumps which are numbers of the selected group to receive a REGEN start command, and if a Fast command is selected (3), then the entire group start will be abandoned if any of the pumps responding in the set are not a G version series pump (with a return of a G or H error code) and, or any of the pumps are currently in regeneration.								
g	[0 - 1]?	<p>Command to disable competing RS-232 ports (1) or allow competing RS-232 ports (0, the default). When a serial port receives the g1 command, the remaining ports will be inhibited from future access to the Network Terminal or the pumps and will reply with either the I or J reply, indicating they are inhibited from responding. Querying the command will result in a return of 0 for no lockout present, and a code of 1, 2, or 3 for a lockout and indication of which port has ownership.</p> <table border="0"> <thead> <tr> <th>Select #</th> <th>Owning Port</th> </tr> </thead> <tbody> <tr> <td>1</td> <td>Host RS-232 port</td> </tr> <tr> <td>2</td> <td>Service RS-232 port</td> </tr> <tr> <td>3</td> <td>Auxiliary RS-232 port</td> </tr> </tbody> </table>	Select #	Owning Port	1	Host RS-232 port	2	Service RS-232 port	3	Auxiliary RS-232 port
Select #	Owning Port									
1	Host RS-232 port									
2	Service RS-232 port									
3	Auxiliary RS-232 port									