



CRITICAL COMPONENTS
GROUP

Granville-Phillips® Series 307 Vacuum Gauge Controller

For Use with Ionization, Convector® and Thermocouple Gauges

VACUUM PRODUCTS

Benefits

- Capable of pressure measurement at up to four locations in your system or process.
- Increased reliability due to conservative design, backed by Brooks' five-year limited warranty.
- Space savings and package design requires only half the conventional rack width.

The Series 307 Vacuum Gauge Controller (VGC) measures pressure, and utilizes pressure-related outputs to control a variety of vacuum system functions and processes. To fit a wide range of needs and applications, the 307 VGC is available in a variety of configurations and prices. In its simplest form the 307 VGC runs a single ionization gauge (IG) in the range from 1×10^{-10} to 1×10^{-1} Torr. With available modules, the 307 controls four gauges, measuring pressure from 2×10^{-11} Torr to atmosphere, and six process control setpoints.

Unique design improvements have resulted in:

- **Capable of pressure measurement** at up to four locations in your system or process using two ionization gauges sequentially and either two Convector Gauges or two thermocouple gauges or one Convector plus one capacitance manometer simultaneously.
- **Excellent system control:** Up to six processes control set points are available and can be enabled automatically at pre-selected pressures or manually.
- **Increased reliability:** dramatically decreased probability of component failure due to conservative design and cooler operating temperature achieved by removing the separately packaged power supply to a remote location. This time proven design is backed by Brooks' five-year limited warranty.
- **Greater safety:** electric shock danger significantly reduced by using only low voltage circuits in the control unit.
- **Improved economy:** modular design enables users to purchase only required capabilities, and allows for easy upgradability in the future.
- **Panel space savings:** only half the conventional rack width is occupied by the 307 control unit. Since no ventilation is required, space above and below the control unit can be used more efficiently.



Granville-Phillips® Series 307 Vacuum Gauge Controller

Figure 1. 307 Control Unit

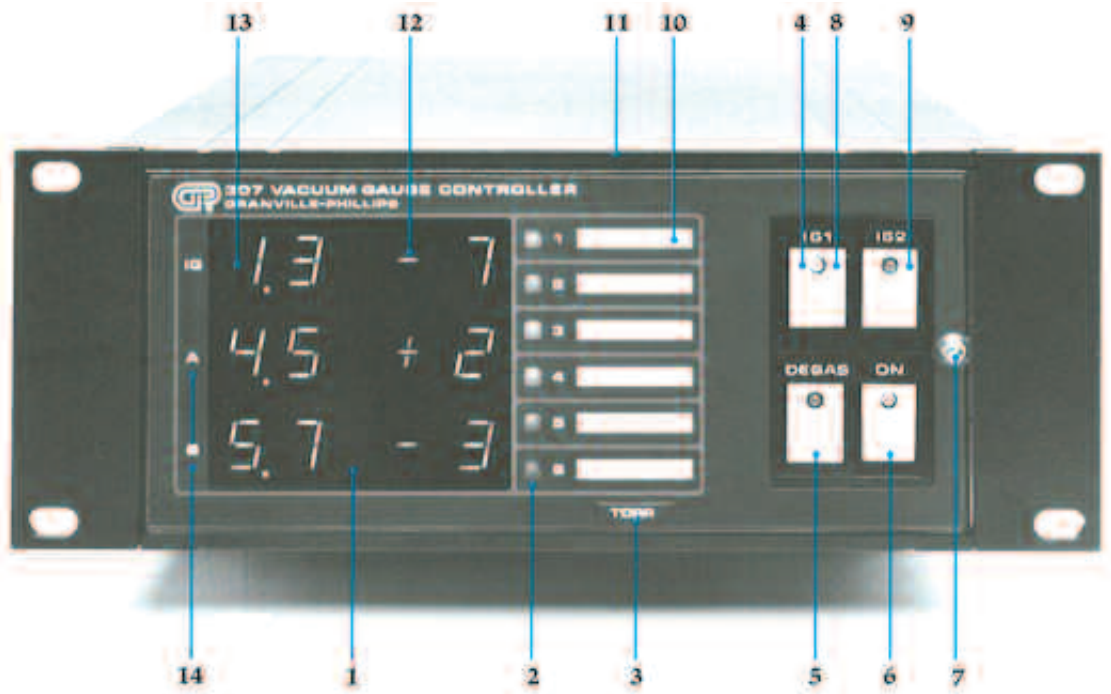

1. All data easily read from 3-in-1 digital display. One glance gives three simultaneous pressure readings.
2. Six available set points provide control of six pressure-related process or system functions: 1, 2 for IG; 3, 4 and 5, 6 for each of two Convectron, thermocouple or capacitance manometer gauges.
3. Unit of measure user selectable: Torr, mbar or Pascal.
4. Greater operational safety: IG grid voltage is present only when filament is on.
5. To suit the cleaning requirements of your gauge tube and pressure range, degas is available, either I'R or EB, specified with order.
6. ON/OFF status clearly indicated by lighted switches.
7. Inside controls protected by lockable front panel.
8. One IG capability included in 307 basic Controller package.
9. Second IG available.
10. User-labeled set point descriptions.
11. Saves valuable panel space: 8.9 cm (3.5 in.) x 24.1 cm (9.5 in.)
12. All controls/readouts clearly labeled for intuitive operation.
13. Ionization gauge readout.
14. Convectron, capacitance manometer or thermocouple gauge readouts.

Greater Flexibility in Mounting

- No ventilation space needed above or below control unit.
- Two control units can be mounted in rack space of one conventional controller.
- power supply can be located anywhere within ten feet of control unit where ventilation is adequate, such as vertically attached to inside wall of system, horizontally on the floor or bottom of system, or rack mounted elsewhere in the panel.

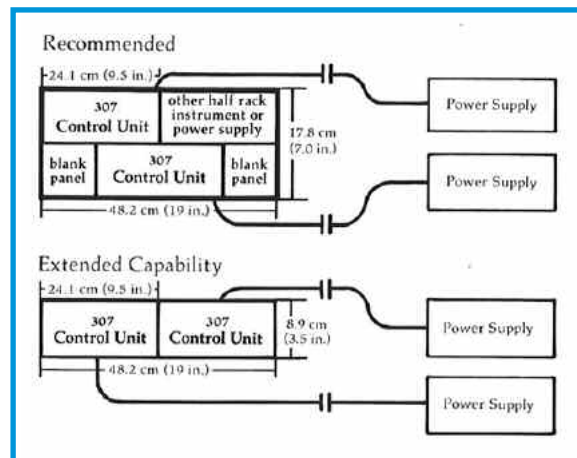
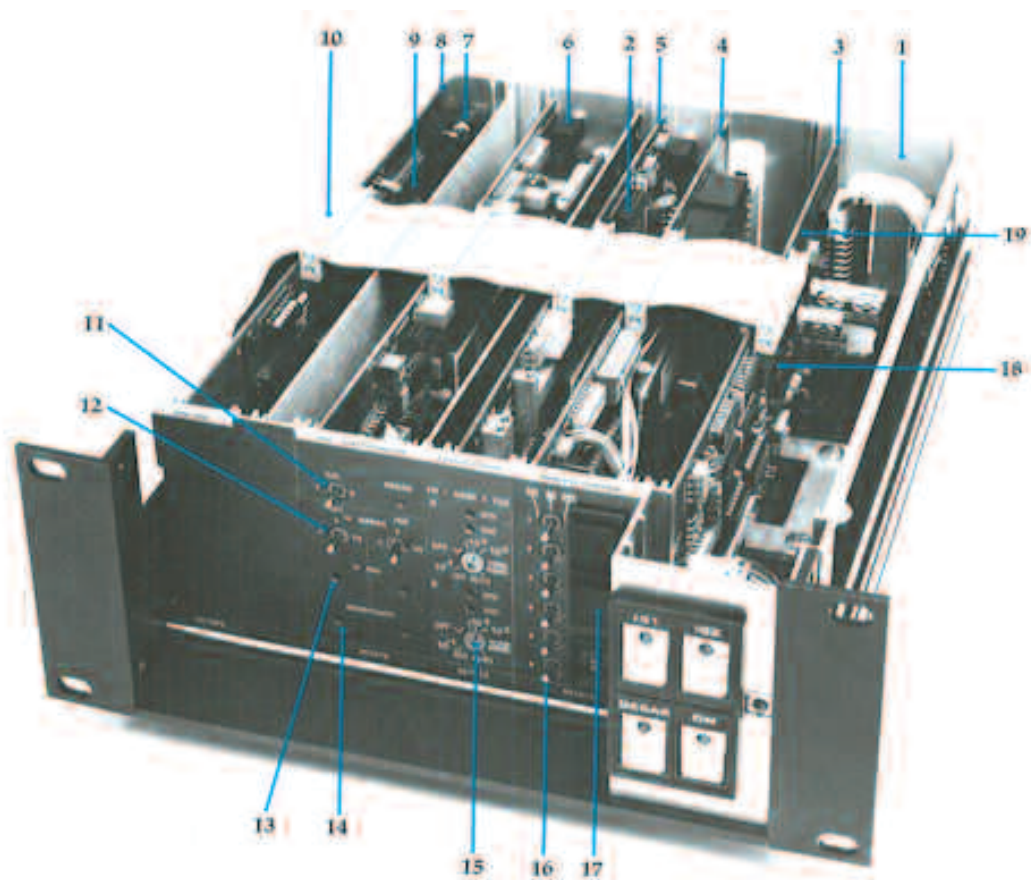

Figure 2. Excellent performance and reliability, intuitive operation and easy, quick maintenance are provided by 307's clean design.



1. Cooler operating temperature since high power-dissipating components are located in the power supply enclosure, not in the control unit.
2. Helps isolate malfunctioning circuits with fault indicators.
3. System control board: voltage regulators, remote and local controls, interface to power supply.
4. Increase process or system control with available control boards for 2 or 6 setpoints, user selectable.
5. Extend upper pressure measurement with available Convectron, capacitance manometer or thermocouple gauge board.
6. Electrometer.
7. Remote reading of pressure and set point status via available computer interface board: RS-232, RS-485 or IEEE-488.
8. Quick repair and minimal downtime with field-replaceable boards.
9. Safer servicing: Maximum of 35 volts DC in control unit.
10. Easy field upgrade with removable connectors.
11. Switch allows viewing of emission current or sensitivity calibration.
12. Improve pressure measurement accuracy with constant emission current; three decade range settings: adjustable from 0.01 mA to 10.0 mA.
13. Continuously adjustable emission control.
14. Adjustable IG tube sensitivity settings to calibrate electrometer for various tube sensitivity factors or for direct readout of various gases.
15. Turn on IG automatically during pump-down with IG auto-on control.
16. Take control of process during set-up or system maintenance with manual override switches for each of up to six process channels.
17. Digital set point controls adjustable for any pressure within the range of associated tube. Digital set points are stable and easy to adjust.
18. Power supply status indicators aid troubleshooting.
19. Low-cost boards are practical to inventory.

More Accurate Pressure Measurement

- Increased pressure measurement accuracy: by controlling emission current, tube temperature is stabilized, thus stabilizing thermal transpiration and its effects, outgassing, and wall charges — each of which could otherwise dramatically affect pressure readings.
- For extended pressure range measurement capability and/or to prolong tube life, emission current can be adjusted. (See Fig. 3).

Figure 3: Operating Range:

The 307 VGC measures pressure and controls systems or processes in the entire operating range from 2×10^{-11} to 990 Torr.

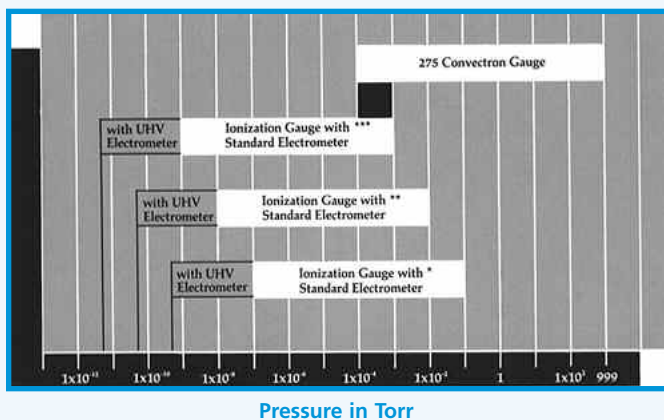

■ Overlapping Convecatron and ionization gauge range for better pressure control. Emission current setting; assumes tube sensitivity of 10/Torr:

- *at 0.1 mA
- **at 1.0 mA
- ***at 10.0 mA.

- Pressure measurements with the Convecatron Gauge are largely immune to temperature changes. A temperature compensation device monitors the gas temperature around the sensing wire rather than monitoring a remote outside wall temperature.
- Each Granville-Phillips Convecatron Gauge Tube is individually calibrated before shipment to be within $\pm 2\%$ of reading over most of its range.
- To improve the accuracy of pressure measurements, sensitivity can be easily adjusted, independent of emission, to match gauge tube calibration.
- Studies¹ have shown Bayard-Alpert type gauges to be 30 to 40% inaccurate. Although the 307 VGC will very accurately measure the ion current, these inaccuracies are inherent in the design of the B-A gauge and cannot be consistently compensated for by any IG controller.

- RF immunity
 - High quality shielded cables are used between the control unit and power supply, and to the gauge tubes.
 - To help prevent electrical disturbance, RF filters are used at critical junctions.
- Less circuit drift and greater pressure measurement accuracy are achieved with a lower temperature rise in the instrumentation enclosure by removing the power supply from the vicinity of the control unit. (See Figure 4).

Figure 4: Longer operating life (less probability of component failures) is a benefit of a remote power supply, and cooler operating temperature.

Granville-Phillips' 307 and various competitive controllers (A-E) with and without space allowed for air ventilation (1-3/4 in. above and below controller).

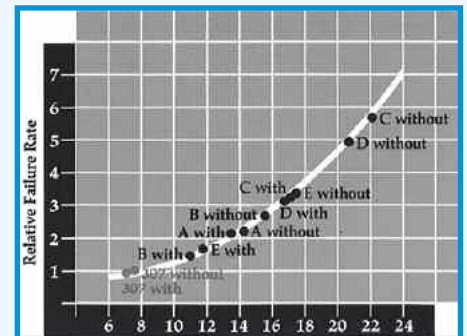

The curve itself is derived from the Arrhenius Model, which is used to predict long-term semiconductor failure mechanisms. It demonstrates that increases in temperature lead to an increase in the probability of component failures. (This assumes that all other variables are held constant.)

Plotted on the line are actual internal temperature readings of the 307 control unit and other available vacuum gauge controllers, with and without space allowed for air ventilation (1-3/4 in. above and below controller).

Improved Economy

- Easy customization — design allows purchase of only those modules needed for current application.
- Easy field upgrade to more complex capabilities at a reasonable cost.
- Saves valuable panel space with small size (half-rack width).
- No extra space required for ventilation since low power dissipation of control unit permits mounting against other instruments.
- Minimal downtime:
 - Locate failed circuits with the help of fault lights.
 - Boards are easy to inventory since each board contains primarily those circuits relevant to its capability.
 - Easily replaceable modules allow quick in-field repair.

1. C.R. Tilford, J. Vac. Sci. Technol. A 1, 152 (1983); P.A. Redhead, J. Vac. Sci. Technol. 6 848 (1969); K.E. McCulloh and C.R. Tilford, J. Var. Sci. Technol. 18, 994 (1981); K.F. Poulter and C.M. Sutton, Vacuum 31, 147 (1981).

Excellent Control

- Enhanced process control with up to 6 set points: 2 on the ionization gauge and 2 on each of two Convector or thermocouple gauges.
- Available Convector or thermocouple gauge capability allows for automatic turn-on of ionization gauge at pre-selected pressure.
- Set points can be overridden manually to facilitate system set-up and maintenance.
- Set point polarity can be user-selected such that relays are activated for pressures either above or below programmed set point.
- Status of set points indicated on front panel; can be identified with user-customized labels.
- Convector Gauge lower limit of 1×10^{-4} Torr, achieved with careful individual zeroing at vacuum, makes this gauge more suitable to control processes such as sputtering in the 1×10^{-3} Torr range.

Increased Reliability

- Supported by Brooks' 5-year limited warranty against defects in materials and workmanship.
- Power-outage protection: all settings are non-volatile so that programmed information is saved in case of power loss or surges. Process control action has selectable relay status so that power-off condition is user-definable. IGs will return to "on" when power recovers, if automatic IG on/off control is in use.
- Damage protection designed-in:
 - Controller protected from short circuits in the gauge tube by special circuitry.
 - Gauge protected from overpressure.
 - Arcs during degas are prevented since plasma build-up causes the control unit to shut down without damage.
- Dramatically decreased probability of component failures due to low operating temperature, achieved by remoting the power supply (see Figure 4).
- A continuous check and automatic recovery for software-related faults provided by designed-in lock-up monitors.

Greater Safety

- Dangerous high voltages are removed from IG electrodes when filament power is off.
- Minimized danger of electric shock provided by remote power supply; control unit runs at less than 35V DC (peak) internally.
- Reduced danger of touching collector lead provided by enclosed cable connector to IG collector. This is important because, if improperly grounded, the collector lead can float at near grid voltage.
- Protection from unauthorized operation provided by tamper-resistant design:
 - Available lockable front panel cover helps protect programmed critical data on sub-panel controls from unauthorized tampering.
 - Remote I/O board allows option of rendering front panel IG and degas controls inoperable.

Convenient Multi-Point Measurement Readout

- Readout of six pressure values shown in close proximity by mounting two control units side-by-side. Each control unit is capable of measuring pressure at up to four points in the system. (See Figure 5).

Figure 5:

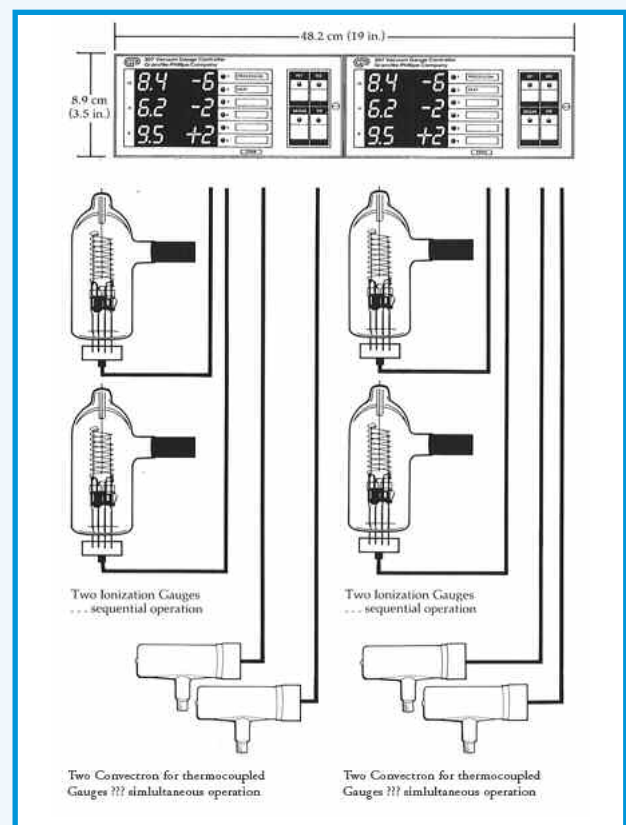

307 Basic Controller Specifications

Display:	
Type	Digital (green LED)
Units	Torr, mbar, Pascal (user-selectable)
Update time	0.5 second typical
Controller Pressure Range	
Lower Measurement Limit	1×10^{-10} Torr with 10 mA emission and tube sensitivity of 10/Torr
Upper Measurement Limit	1×10^{-1} Torr with 0.1 mA emission and tube sensitivity of 10/Torr
Pressure Range	7 decades within above limits for given emission setting and tube sensitivity
Emission Current	Controlled, adjustable from 0.01 to 10.0 mA
Ionization Gauge	Analog output, Logarithmic: 1V/decade, 0-10 VDC Bayard-Alpert (B-A) and other compatible hot filament-type ionization gauges
Sensitivity Adjustment Range	3/Torr to 50/Torr
Standard Electrometer	Sensitivity and emission adjustment for IG tube
Cables	3 m (10 ft.), 7.6 m (25 ft.), 15.2 m (50 ft.) or specify up to 61 m (200 ft.)
Control Unit Dimensions	8.9 cm (3.5 in.) high 24.1 cm (9.5 in.) wide 27.3 cm (10.75 in.) deep [allow +5 cm (+2 in.) depth for connectors]
Power Supply Dimensions	8.9 cm (3.5 in.) high 20.3cm (8 in.) wide, without mounting brackets 24 cm (9.5 in.) deep
Operating Temperature	40°C maximum ambient
Power Input	100/115/230 \pm 10% VAC (user-specified) 250 watts 50 or 60 Hz
Additional Available Module and Function Specifications	
Available Computer Interfaces	<ul style="list-style-type: none"> • IEEE-488 (parallel) • RS-232 or RS-485 (serial) • Baud rates: 75 (RS-232 only), 150, 300, 600, 1200, 2400, 3600, 4800 or 9600 selectable; 19.2k (RS-485 only) • For pressure data output and set point status • Provides remote ON/OFF control for IG1, IG2 and degas
High Performance Ultra High Vacuum (UHV) Electrometer	<ul style="list-style-type: none"> • Extends pressure readout limit to 2×10^{-11} Torr with 10 mA of emission • Provides Electron Bombardment Degas power adjustment control • Contains separate sensitivity adjustments and separate emission controls for independent control of two ion gauges
High Pressure Operation	<ul style="list-style-type: none"> • Readout resolution to two significant digits over entire range of applicable gauge (except 10^{-4} Torr range)
Convectron Gauge Function	<ul style="list-style-type: none"> • Operates two Granville-Phillips' 275 gauge tubes • Pressure range: 1×10^{-4} to 990 Torr • Temperature: <ul style="list-style-type: none"> - bake-out up to 150°C (non-operational) - operating 4-50°C - tube environmental compensating range 15-50°C • Keyed connector for easy transducer installation (even in "blind" locations) • Analog output, Logarithmic: 1V/decade, 0-7 VDC. Adjustable offset of +1 to -7 VDC.
Thermocouple Gauge Function	<ul style="list-style-type: none"> • Operates two Granville-Phillips' 270 gauge tubes • Pressure range: 1×10^{-3} to 1 Torr • Analog output, non-linear: 0-10 VDC <p>Note: Both the Convectron and thermocouple gauge board options include automatic ion gauge turn-on capability.</p>
Capacitance Manometer Function	<ul style="list-style-type: none"> • Operates one GP 275 gauge tube and one Capacitance Manometer. • Maximum capacitance manometer range: 1 - 10 - 100 - 1,000 Torr • +/- 15VDC 250mA Power Supply
Process Controls	<ul style="list-style-type: none"> • Two channel (for IG only) • Six channel (for all gauges) • Pressure-related relays (set points) enabled at user-selected pressures • Relay configuration: SPDT (single pole, double throw) • Relay contact rating: 250V AC; 5A resistive load 30V DC; 5A Gold plated contacts for low level switching
Two Ion Gauge Operation	<ul style="list-style-type: none"> • Two tube sequential operation • Hot filament-type ionization gauges, such as Bayard-Alpert
Remote Input/Output	<ul style="list-style-type: none"> • Provides status relay contacts for IG1, IG2, fault detection • Provides remote ON/OFF control for IG1, IG2, and degas • Provides lockout of front panel switches
Degas	<ul style="list-style-type: none"> • Electron Bombardment (EB)*: 10-40 watts adjustable • I²R: 8V nominal, (fixed) 80 watts maximum <p>* If EB degas is selected the UHV Electrometer is recommended to provide for degas power adjustment independent of emission current settings</p>

Choose one of the basic controllers and add the options below to create your catalog number.

Configured for Series 274 glass tubulated or nude (not UHV) Bayard-Alpert gauges with resistive degas:

Left mount, side-by-side with power supply for 19-inch rack	307502 - # # # - # #
Half-rack mount, remote power supply	307501 - # # # - # #

Configured for Series 274 UHV nude Bayard-Alpert gauges with electron bombardment degas, UHV electrometer (reads to 2x10⁻¹¹ Torr)

Left mount, side-by-side with power supply for 19-inch rack	307508 - # # # - # #
Half-rack mount, remote power supply	307507 - # # # - # #

Interface Options (Slot X):

None	0
RS-232	A
RS-485	B
IEEE-488	C
Linear Analog Output	D

Gauge Options (Slot Y):

None	0
Dual Convector	1
Convector / Capacitance Diaphragm	2
Dual Thermocouple	3

Setpoint Options (Slot Z):

None	0
2 setpoint relays for ion gauge	A
6 setpoint relays, 2 per channel	B
6 setpoint relays, user configurable	C

Display Options - Measurement units:

Torr	T
mbar	M
Pa	P

Power Cord Options:

North America 115 V	1
North America 240 V	2
Universal Europe 220 V	3
United Kingdom 240 V	4

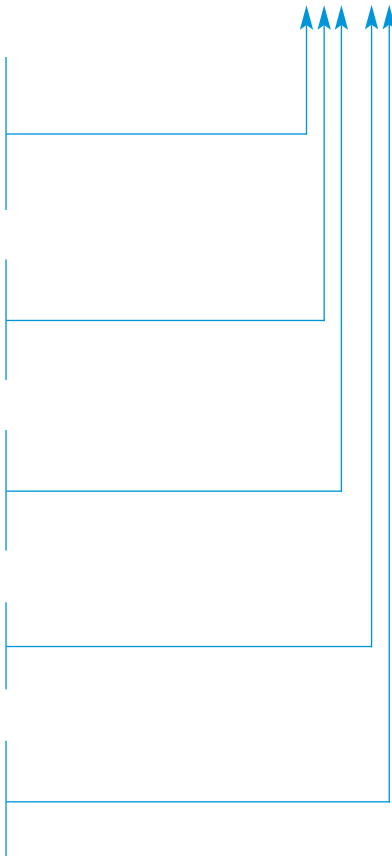

Example: To order a Series 307 Vacuum Gauge Controller with half-rack mount, remote power supply, resistive degas, linear analog output, dual Convector Gauge operation, 6 setpoint relays, display in Torr, and North America 115 V power cord, select catalog number: 307501-D1B-T1

Option Cards (for field installation)

RS-232 computer interface	307019
IEEE-488 computer interface	307020
Linear analog output for thermocouple and ionization gauges	307100
Dual Convector Gauge	307013
Convector Gauge/capacitance diaphragm gauge	307026
Dual Thermocouple Gauge	307014
Process control with 2 setpoint relays for ionization gauge	307018
Process control with 6 setpoint relays, 2 per channel	307017
Process control with 6 setpoint relays, user configurable	307269
Remote control interface	307012

Optional Installation Rack-Mount Hardware (for field installation)

Power supply and control unit side-by-side for 19-inch rack	307009
Control unit on the left or right side for 19-inch rack	307010
Control unit in the center of 19-inch rack	307011
2 control units side-by-side for 19-inch rack	307021
1 or 2 power supplies for 19-inch rack	307008
Power supply in half-rack panel	307114

Thermocouple Gauges

DV6-R, with metal alignment key (the metal thermocouple body is brazeable Monel) 270006

Cables for Tubulated Glass Ionization Gauges

For side-by-side mounting

10 feet (3 meters)	307042
25 feet (7.6 meters)	307043
50 feet (15.2 meters)	307044

For remote mounting of power supply

10 feet (3 meters)	307030
25 feet (7.6 meters)	307031
50 feet (15.2 meters)	307032

Cables for Nude Ionization Gauges

With push-on pins, side-by-side mounting

10 feet (3 meters)	307046
25 feet (7.6 meters)	307047
50 feet (15.2 meters)	307048

With push-on pins, remote mounting of power supply

10 feet (3 meters)	307034
25 feet (7.6 meters)	307035
50 feet (15.2 meters)	307036

With pin guard/locking strain relief for EB degas, side-by-side mounting

10 feet (3 meters)	307046-CE*
25 feet (7.6 meters)	307047-CE*
50 feet (15.2 meters)	307048-CE*

With pin guard/locking strain relief for EB degas, remote mounting of power supply

10 feet (3 meters)	307034-CE*
25 feet (7.6 meters)	307035-CE*
50 feet (15.2 meters)	307036-CE*

With pin guard/locking strain relief for resistive degas, side-by-side mounting

10 feet (3 meters)	307046-CR*
25 feet (7.6 meters)	307047-CR*
50 feet (15.2 meters)	307048-CR*

* Bakeable to 150°C. For higher temperature bakeable cables contact Brooks Customer Support.

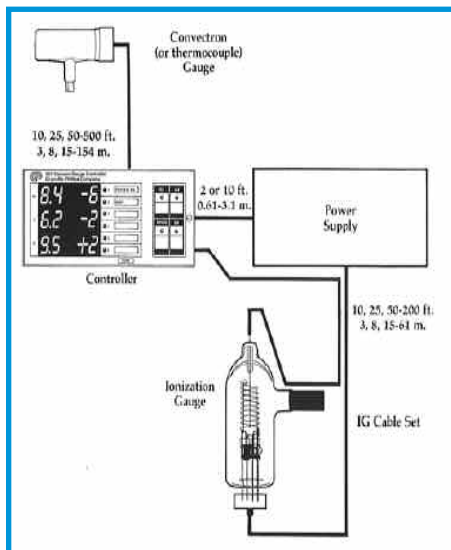

Cables for:

Dual Convectron Gauges

10 feet (3 meters)	303040-10
25 feet (7.6 meters)	303040-25
50 feet (15.2 meters)	303040-50
100 feet (30.5 meters)	303040-100
200 feet (61 meters)	303040-200

Dual thermocouple gauges

10 feet (3 meters)	307054
25 feet (7.6 meters)	307055
50 feet (15.2 meters)	307056

Convectron Gauge / capacitance diaphragm gauge

10 feet (3 meters)	307027
25 feet (7.6 meters)	307028
50 feet (15.2 meters)	307029

IEEE-488

3.3 feet (1 meter)	303042
6.6 feet (2 meters)	303043
13.2 feet (4 meters)	303044

Backed by GUTS®

All Granville-Phillips products are backed by the GUTS (Guaranteed Uptime Support) rapid response network, our comprehensive customer support program. When you call the GUTS service center, you are guaranteed immediate, competent response and action by a vacuum expert from our world-wide technical support staff. We're at work for you 24 hours a day, 365 days a year. 1-800-FOR-GUTS (800-367-4887).

*For more information, please contact your local
Brooks Automation sales representative or visit www.brooks.com.*

