

Series 354

Granville-Phillips® Series 354 Micro-Ion® Vacuum Gauge Module with Analog Output



Instruction Manual

Instruction manual part number 354004

Revision 06 - May 2008

Series 354

Granville-Phillips® Series 354 Micro-Ion® Vacuum Gauge Module with Analog Output

This Instruction Manual is for use with all Granville-Phillips Series 354 Micro-Ion Vacuum Gauge Modules with analog output. A list of applicable catalog numbers is provided on the following page.

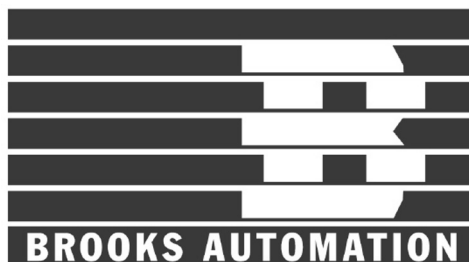

Customer Service/Support

For customer service, 24 hours per day, 7 days per week, every day of the year including holidays, toll-free within the USA, phone 1-800-367-4887

For customer service within the USA, 8 AM to 5 PM, weekdays excluding holidays:

- Toll-free, phone: 1-800-776-6543
- Phone: 1-303-652-4400
- FAX: 1-303-652-2844
- Email: co-csr@brooks.com
- World Wide Web: www.brooks.com

Instruction Manual

Granville-Phillips® Series 354 Micro-Ion® Vacuum Gauge Module with Analog Output

Catalog numbers for Series 354 Micro-Ion Modules - CE Marked

Power supply and cable are not included.

Analog output, no setpoint relays:

No digital display	354001 - X X - X
3-digit display	354002 - X X - X

RS-485 interface, 1 setpoint relay:

No digital display (Torr only)	354005 - X X - T
--------------------------------	------------------

DeviceNet interface, 2 setpoint relays:

No digital display	354009 - X X - X
3-digit display	354006 - X X - X

Filaments:

dual yttria-coated iridium
dual tungsten

Y
T

Flange/Fitting:

NW16KF
NW25KF
NW40KF
1.33 inch (NW16CF) Conflat-type
2.75 inch (NW35CF) Conflat-type
1/2 inch VCR-type male
NW16L
40KFL

D
E
K
F
G
H
M
L

Measurement Units:

Torr
mbar
pascal

T
M
P

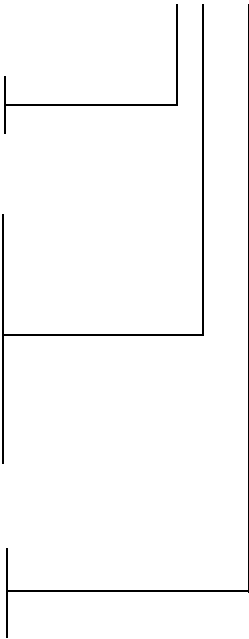

Conflat is a registered trademark of Varian Associates
VCR, VCO are registered trademarks of Cajon Co.

Table of Contents

- Chapter 1 Safety Instructions7
 - 1.1 Safety Introduction7
 - 1.2 Damage Requiring Service8
 - 1.3 Warranty Information10
 - 1.4 Service Guidelines10
 - 1.5 FCC Verification10

- Chapter 2 Installation11
 - 2.1 Introduction11
 - 2.2 Mounting11
 - 2.3 Fittings12
 - 2.4 Grounding12
 - 2.5 I/O Cable Connections13

- Chapter 3 Operation15
 - 3.1 Theory of Operation15
 - 3.2 Gauge ON/OFF15
 - 3.3 Power Indicator LED16
 - 3.4 Emission Current16
 - 3.5 Analog Output17
 - 3.5.1 Analog Output for Catalog Number 2035401519
 - 3.5.2 Analog Output for Catalog Numbers 354019 and 2035401420
 - 3.6 Gas Sensitivity Correction21
 - 3.6.1 Example21
 - 3.7 Overpressure Shutdown21
 - 3.8 Very-High and Ultra-High Vacuum Measurement21
 - 3.9 Degas22
 - 3.9.1 Degas for Catalog Numbers 20354014 and 35401922
 - 3.10 Filament Selection22
 - 3.10.1 Filament Selection for Catalog Numbers 20354014 and 35401922
 - 3.11 Specifications for the Micro-Ion Gauge Module23

- Chapter 4 Service and Maintenance25
 - 4.1 Service Guidelines25
 - 4.2 Damage Requiring Service26
 - 4.3 Troubleshooting27
 - 4.4 Ion Gauge Continuity Test28
 - 4.5 Fuse Replacement30
 - 4.6 Gauge Replacement31
 - 4.7 Returning a Micro-Ion Module for Service32

- Index33

Chapter 1

Safety Instructions

1.1 Safety Introduction

START BY READING THESE IMPORTANT SAFETY INSTRUCTIONS AND NOTES collected here for your convenience and repeated with additional information at appropriate points in these instructions.

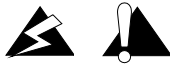

These safety alert symbols in this manual or on the Product rear panel, mean caution - personal safety, property damage or danger from electric shock. Read these instructions carefully.

In these instructions the word “product” refers to the Micro-Ion Vacuum Gauge Module and all of its approved parts and accessories.

NOTE: These instructions do not and cannot provide for every contingency that may arise in connection with the installation, operation, or maintenance of this product. Should you require further assistance, please contact Brooks Automation, Inc./Granville-Phillips at the address on the title page of this manual.

This product has been designed and tested to offer reasonably safe service provided it is installed, operated, and serviced in strict accordance with these safety instructions.



Failure to comply with these instructions may result in serious personal injury, including death, or property damage.

These safety precautions must be observed during all phases of operation, installation, and service of this product. Failure to comply with these precautions or with specific warnings elsewhere in this manual violates safety standards of design, manufacture, and intended use of the instrument. Brooks Automation, Inc./Granville-Phillips disclaims all liability for the customer's failure to comply with these requirements.



The service and repair information in this manual is for the use of Qualified Service Personnel. To avoid shock, do not perform any procedures in this manual or perform any servicing on this product unless you are qualified to do so.

- **Read Instructions** – Read all safety and operating instructions before operating the product.
- **Retain Instructions** – Retain the Safety and Operating Instructions for future reference.
- **Heed Warnings** – Adhere to all warnings on the product and in the operating instructions.
- **Follow Instructions** – Follow all operating and maintenance instructions.
- **Accessories** – **Do not** use accessories not recommended in this manual as they may be hazardous.



To reduce the risk of fire or electric shock, do not expose this product to rain or moisture.



Objects and Liquid Entry - Never push objects of any kind into this product through openings as they may touch dangerous voltage points or short out parts that could result in a fire or electric shock. Be careful not to spill liquid of any kind onto the products.

Do not substitute parts or modify instrument.



Because of the danger of introducing additional hazards, do not install substitute parts or perform any unauthorized modification to the product. Return the product to a service facility designated by Granville-Phillips for service and repair to ensure that safety features are maintained. Do not use this product if it has unauthorized modifications.

1.2 Damage Requiring Service

Disconnect the product from all power sources and refer servicing to Qualified Service Personnel under the following conditions:

- a. When any cable or plug is damaged.
- b. If any liquid has been spilled onto, or objects have fallen into, the product.
- c. If the product has been exposed to rain or water.
- d. If the product does not operate normally even if you follow the operating instructions. Adjust only those controls that are covered by the operation instructions. Improper adjustment of other controls may result in damage and will often require extensive work by a qualified technician to restore the product to its normal operation.
- e. If the product has been dropped or the enclosure has been damaged.
- f. When the product exhibits a distinct change in performance. This indicates a need for service.



Replacement Parts - When replacement parts are required, be certain to use the replacement parts that are specified by Granville-Phillips, or that have the same characteristics as the original parts. Unauthorized substitutions may result in fire, electric shock or other hazards.



Safety Check - Upon completion of any service or repairs to this product, ask the Qualified Service Person to perform safety checks to determine that the product is in safe operating order.



Finite Lifetime - After ten years of normal use or even non-use, the electrical insulation in this product may become less effective at preventing electrical shock. Under certain environmental conditions which are beyond the manufacturer's control, some insulation material may deteriorate sooner. Therefore, periodically inspect all electrical insulation for cracks, crazing, or other signs of deterioration. Do not use if the electrical insulation has become unsafe.



Be aware that when high voltage is present in any vacuum system, a life threatening electrical shock hazard may exist unless all exposed conductors are maintained at earth ground.

This hazard is not peculiar to this product.



Be aware that an electrical discharge through a gas may couple dangerous high voltage directly to an ungrounded conductor almost as effectively as would a copper wire connection. A person may be seriously injured or even killed by merely touching an exposed ungrounded conductor at high potential.

This hazard is not unique to this product.

**Proper Grounding:**

All components of a vacuum system used with this or any similar high voltage product must be maintained at earth ground for safe operation. Be aware that grounding this product does not guarantee that other components of the vacuum system are maintained at earth ground.

Verify that the vacuum port to which the Micro-Ion Module is mounted is electrically grounded. It is essential for personnel safety as well as proper operation that the envelope of the gauge be connected to a facility ground. Use a ground lug on a flange bolt if necessary.



All conductors in, on, or around the vacuum system that are exposed to potential high voltage electrical discharges must either be shielded at all times to protect personnel or must be connected to earth ground at all times.



Danger, High Voltage – The high voltages present within the Power Supply are capable of causing injury or death. To avoid electric shock, wait 3 minutes after power is removed before touching any component within the Power Supply. This will permit charged capacitors to discharge.



Danger, high voltage – 180V is present in the Power Supply, on the cable, and at the ion gauge when the gauge is turned on. Voltages as high as 250V peak are present during degas.



Install suitable devices that will limit the pressure to the level that the vacuum system can safely withstand. In addition, install suitable pressure relief valves or rupture disks that will release pressure at a level considerably below the pressure that the system can safely withstand.

Suppliers of pressure relief valves and pressure relief disks are listed in the *Thomas Register* under “Valves, Relief”, and “Discs, Rupture”.

Confirm that these safety devices are properly installed before installing the product. In addition, check that:

- (1) the proper gas cylinders are installed,
- (2) gas cylinder valve positions are correct on manual systems, and
- (3) the automation is correct on automated gas delivery systems.

Vacuum gauges with compression fittings may be forcefully ejected if the vacuum system is pressurized.



Caution: If the overpressure shutdown point is increased from the factory settings, an excess pressure rise may go undetected—resulting in possible gauge and/or vacuum system damage. Consult the factory if in doubt.



It is the installer's responsibility to ensure that the automatic signals provided by the product are always used in a safe manner. Carefully check the system programming before switching to automatic operation.



Where an equipment malfunction could cause a hazardous situation, always provide for fail-safe operation. As an example, in an automatic backfill operation where a malfunction might cause high internal pressures, provide an appropriate pressure relief device.



The fumes from solvents such as trichloroethylene, perchloroethylene, toluene, and acetone can be dangerous to health if inhaled. Use only in well ventilated areas exhausted to the outdoors. Acetone and toluene are highly flammable and should not be used near an open flame or energized electrical equipment.

1.3 Warranty Information

Brooks Automation, Inc. provides an eighteen (18) month warranty from the date of shipment for new Granville-Phillips Products. The Brooks Automation, Inc. General Terms and Conditions of Sale provides the complete and exclusive warranty for Brooks Automation, Inc./Granville-Phillips products. This document may be located on our web site at www.brooks.com, or may be obtained by contacting a Brooks Automation, Inc./Granville-Phillips Customer Service Representative.

1.4 Service Guidelines

Some minor problems are readily corrected on site. If the product requires service, please contact our Customer Service Department at 303-652-4400 for troubleshooting help over the phone.

If the module must be returned to the factory for service, request a Return Authorization (RA) from Brooks Automation / Granville-Phillips. Do not return products without first obtaining an RA. In some cases a hazardous materials document may be required. The Brooks Automation / Granville-Phillips Customer Service Representative will advise you if the hazardous materials document is required.

When returning equipment to Brooks Automation / Granville-Phillips, be sure to package the products to prevent shipping damage. Circuit boards and modules separated from the controller chassis must be handled using proper anti-static protection methods and must be packaged in anti-static packaging. Brooks Automation / Granville-Phillips will supply return packaging materials at no charge upon request. Shipping damage on returned products as a result of inadequate packaging is the Buyer's responsibility. **Before you return the module**, obtain an RA number by contacting Granville-Phillips customer service:

- Phone **1-303-652-4400** or **1-800-776-6543** within the USA.
- Phone **1-800-367-4887** 24 hours per day, seven days per week within the USA.
- Email **co-csr@brooks.com**
- For Global Customer Support, go to www.brooks.com, click on Contact Us, then click on Global Offices to locate the Brooks Automation office nearest you.

1.5 FCC Verification

This equipment has been tested and found to comply with the limits for a Class A digital device, pursuant to Part 15 of the FCC Rules. These limits are designed to provide reasonable protection against harmful interference when the equipment is operated in a commercial environment. This equipment generates, uses, and can radiate radio frequency energy and, if not installed and used in accordance with this instruction manual, may cause harmful interference to radio communications. However, there is no guarantee that interference will not occur in a particular installation. Operation of this equipment in a residential area is likely to cause harmful interference in which case the user will be required to correct the interference at his own expense. If this equipment does cause harmful interference to radio or television reception, which can be determined by turning the equipment off and on, the user is encouraged to try to correct the interference by one or more of the following measures:

- Reorient or relocate the receiving antenna.
- Increase the separation between the equipment and the receiver.
- Connect the equipment into an outlet on a circuit different from that to which the receiver is connected.
- Consult the dealer or an experienced radio or television technician for help.

Chapter 2

Installation

2.1 Introduction

The Micro-Ion Gauge Module measures pressures from less than 1×10^{-9} Torr to 5×10^{-2} Torr, N_2 equivalent (or air). Pressure readout is via a logarithmic analog voltage on the I/O connector on all models and digital readout for models with that option. Filament selection is via a selector switch adjacent to the "D" connector.

The Micro-Ion Gauge Module is a modular instrument intended for computer control only with no external controls or adjustments. The power supply voltage required for operation is 24 Vdc, $\pm 15\%$, 12 watts.

2.2 Mounting

The Micro-Ion Gauge Module can be mechanically mounted anywhere in a system in any attitude. It should be mounted in a location with free air flow and ambient temperature less than 40°C .

The Micro-Ion Gauge Module is mounted to the vacuum system by the flange only. Reasonable care should be taken to install the device where it is protected from physical damage.

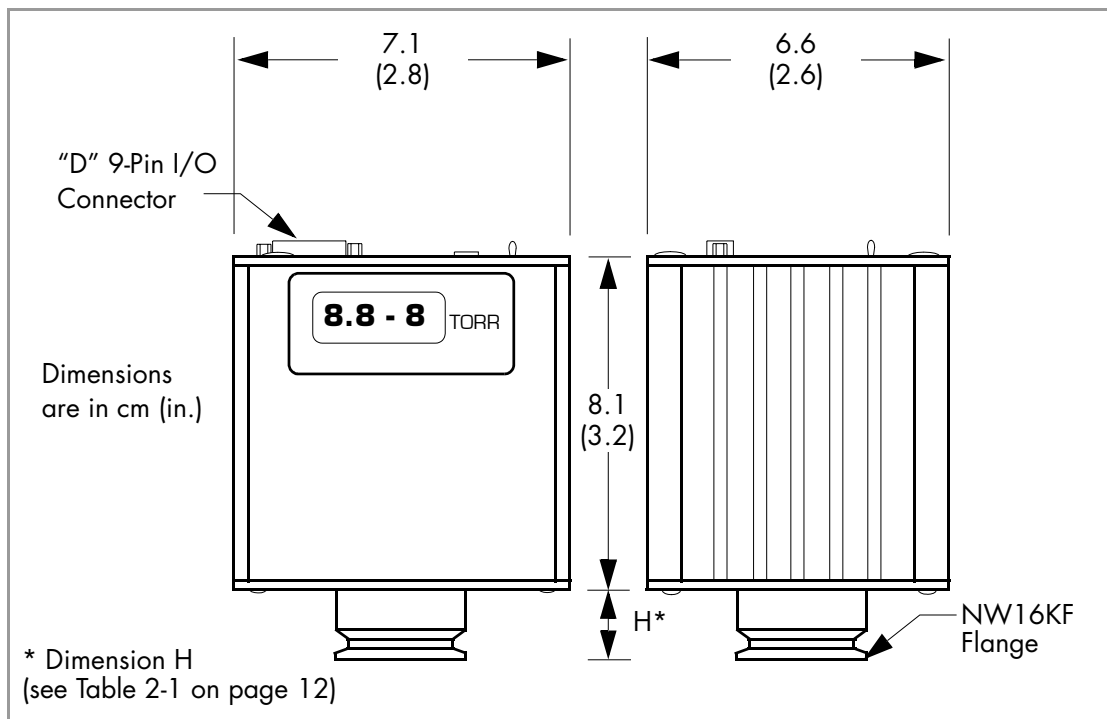

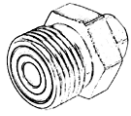

Figure 2-1 Micro-Ion Gauge Module Dimensions.

2.3 Fittings

Table 2-1 Fittings for Micro-Ion Gauge Module.

Fitting	Description	Dimension H
	NW16KF flange NW25KF flange NW40KF flange	2.0 cm (0.8 in.) 2.0 cm (0.8 in.) 2.0 cm (0.8 in.)
	1.33 in. (NW16CF) ConFlat-type flange 2.75 in. (NW35CF) ConFlat-type flange	4.3 cm (1.7 in.) 4.3 cm (1.7 in.)
	1/2 inch VCR-type male	5.8 cm (2.3 in.)

All dimensions are nominal. For tolerances, contact Granville-Phillips.

2.4 Grounding

The Micro-Ion Gauge Module converts the input power to +180 Vdc for the grid supply (+250 Vdc during degas). For safety the outer housing of the gauge must be grounded to the vacuum chamber. This is accomplished by the use of a metal flange clamp for the NW16KF and NW25KF flanges. Due to the "O" ring seal, grounding cannot be assumed through the fitting. The groove in the KF flange of the Micro-Ion Gauge Module has been designed to prevent the use of a non-metallic type of flange clamp. Do not alter the groove or a non-metallic flange clamp to attempt usage.

VCR, VCO are registered trademarks of Cajon Co.; Conflat is a registered trademark of Varian Associates

2.5 I/O Cable Connections

The I/O connector is used to operate the Micro-Ion Gauge Module and output the analog voltage corresponding to pressure.

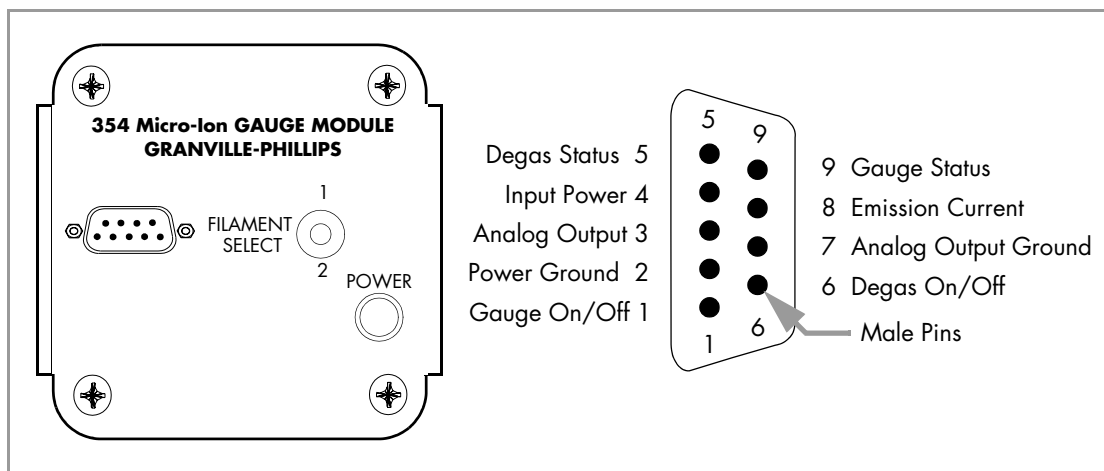

Figure 2-2 Micro-Ion Gauge Module Analog Connector.

Table 2-2 I/O Connector Pin Descriptions.

Pin	Description	Function
1	Gauge On/Off	The application of a continuous ground is required for an "ON" condition. Removal of the ground turns the gauge off.
2	Power Ground	Use for input power return, IG ON/OFF, Degas ON/OFF, and status outputs.
3	Analog Output	Used in conjunction with Pin 7, Analog Output Ground.
4	Input Power	+24 Vdc \pm 15%, 12 watts max. Protected against reversal and overvoltage.
5	Degas Status	Open collector transistor (grounded emitter) rated at 40 V max. VCE, 50 mA max. Transistor OFF = degas OFF, transistor ON = degas ON.
6	Degas ON/OFF	Application of Ground turns degas "ON".
7	Analog Output Ground	Use in conjunction with the analog output only.
8	Emission Current	Application of a ground increases emission current from 100 μ A to 4 mA.
9	Gauge Status	Open collector transistor (grounded emitter) rated at 40 V max. VCE, 50 mA max. Transistor OFF = Gauge OFF, transistor ON = Gauge ON. NOTE: For Catalog Numbers 20354014 and 354019, Pin 9 is for FILAMENT SELECT. Assert low (to Power Ground, Pin 2) to select FILAMENT 2. Allow this pin to float high or pull to logic high level for FILAMENT 1 to be selected. This function is active only if the FILAMENT SELECT switch is in the REMOTE position. No Gauge Status line is provided for these products.

NOTES

Chapter 3

Operation

3.1 Theory of Operation

The functional parts of a typical ionization gauge are the filament (cathode), grid (anode) and ion collector, which are shown schematically in Figure 3-1. These electrodes are maintained by the gauge controller at +30, +180, and 0 volts, relative to ground, respectively.

The filament is heated to such a temperature that electrons are emitted, and accelerated toward the grid by the potential difference between the grid and filament. All of the electrons eventually collide with the grid, but many first traverse the region inside the grid many times.

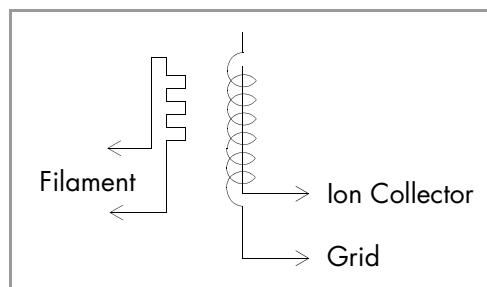

Figure 3-1 Ion Gauge Schematic.

When an energetic electron collides with a gas molecule an electron may be dislodged from the molecule leaving it with a positive charge. Most ions are then accelerated to the collectors. The rate at which electron collisions with molecules occur is proportional to the density of gas molecules, and hence the ion current is proportional to the gas density (or pressure, at constant temperature).

The amount of ion current for a given emission current and pressure depends on the ion gauge design. This gives rise to the definition of ion gauge "sensitivity", frequently denoted by "K":

$$K = \text{ion current} / (\text{emission current} \times \text{pressure})$$

Micro-Ion Gauges have a sensitivity of 20/Torr when used with nitrogen or air.

The ion gauge controller varies the heating current to the filament to maintain a constant electron emission, and measures the ion current to the collector. The pressure is then calculated from these data.

Ion gauge degas is accomplished by increasing the emission current to 15 mA and raising the grid bias to 250 Vdc resulting in an increased temperature of the grid to drive off absorbed gases.

3.2 Gauge ON/OFF

To turn the gauge ON, it is required that pin 1 be grounded to pin 2 of the I/O connector. To turn the gauge OFF, remove the ground. Note that the application of the ground will only try to turn the gauge ON once. If, for any reason, this is not successful, it will be required that the input be recycled back to OFF and then ON again.

Possible reasons for an unsuccessful turn-on to happen include:

1. Slow voltage rise from the power supply to the unit. Try again.
2. Attempt made to turn on the gauge at a pressure where emission could not be established.
3. An overpressure shutdown where system pressure exceeded the overpressure shutdown level.

3.3 Power Indicator LED

The power indicator LED on Micro-Ion modules shows the status of power, ion gauge, and operating pressure.

The power indicator LED state for all Micro-Ion modules are given in Table 3-1 (*with the exceptions* of Catalog Numbers 20354014 and 354019, which are stated in Table 3-2).

Table 3-1 *Power Indicator Status LED for Micro-Ion Modules (with the Exceptions of Catalog Numbers 20354014 and 354019).*

LED Status	Description
OFF	Module not powered.
Steady GREEN	Power applied, ion gauge ON.
Blinking GREEN	Electronics Failure.

Table 3-2 *Power Indicator Status LED for Micro-Ion Modules Catalog Numbers 20354014 and 354019.*

LED Status	Description
OFF	Module not powered.
Steady RED	Power applied, ion gauge OFF.
Steady ORANGE	Ion gauge ON, pressure above 1×10^{-4} Torr.
Steady GREEN	Ion gauge ON, pressure below 1×10^{-4} Torr.

3.4 Emission Current

There are two ranges of emission current available. Either 100 microamperes or 4 milliamperes are available as determined by the status of pin 8 of the I/O connector. While either range can be used continuously, the following guidelines are suggested. For operation in the higher pressure ranges with a clean system 100 microamperes emission is satisfactory. For operation in the lower pressure ranges the 4 milliamperes range should be used to give a more accurate pressure reading. Internal circuitry corrects the analog output voltage to pressure relationship curve for the emission current selected.

There is a problem with all ion gauges when used in systems which have the potential for diffusion pump oil vapor to enter the gauge volume. This oil vapor deposits on the grid forming an insulator and preventing emission resulting in higher and higher filament power being required and ultimate inability to control emission. In this situation, the 4 milliamperes position is recommended.

3.5 Analog Output

The analog output for all Micro-Ion Gauge Modules (*with the exceptions* of Catalog Numbers 20354014, 20354015, and 354019) is a 0-9 Vdc signal proportional to the logarithm of the pressure with 0 volts at 1×10^{-10} Torr.

NOTE: Refer to Section 3.5.1 on page 19 for the analog output for Micro-Ion module Catalog Number 20354015.

NOTE: Refer to Section 3.5.2 on page 20 for the analog output for Micro-Ion module Catalog Number 354019 and 20354014.

With a 0-9 Vdc output, the equation for pressure is:

$$\text{Pressure} = 10^{(\text{volts}-10)}$$

- When the Micro-Ion gauge is turned OFF, the output will switch to slightly over +10 Vdc.
- During an overpressure shutdown, the output will also switch to slightly over +10 Vdc.
- During degas, the overpressure shutdown occurs at 3×10^{-4} .
- At 4mA emission, the overpressure shutdown occurs at 1.5×10^{-3} .
- At 100 μ A emission, the overpressure shutdown occurs at 5×10^{-2} .

Figure 3-2 on page 18 shows the standard Micro-Ion Modules' pressures for Degas, 4 mA Emission, and 100 μ A Emission, where the overpressure shutdown occurs.

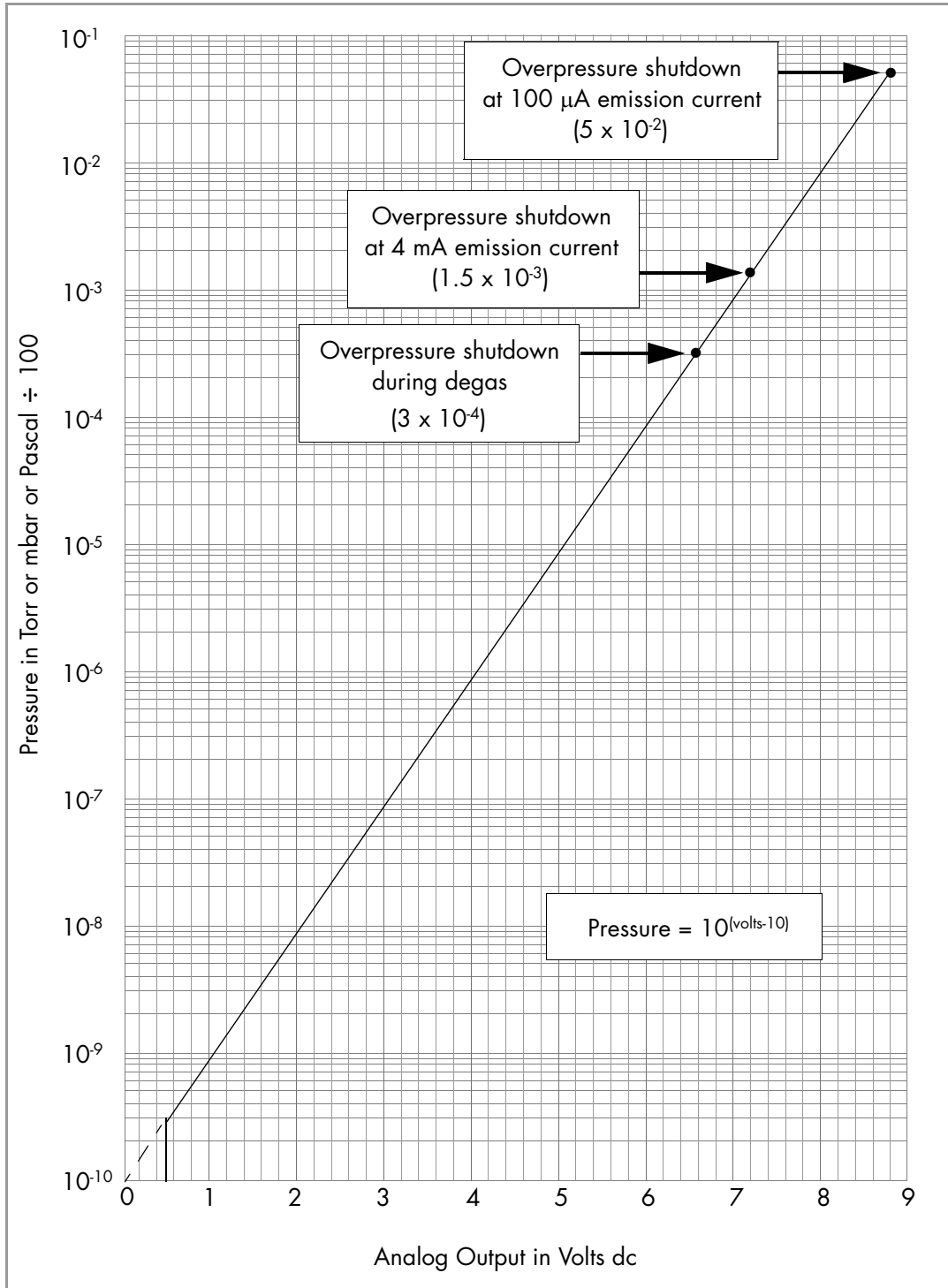

Figure 3-2 Analog Output Curve for Standard Micro-Ion Modules.

3.5.1 Analog Output for Catalog Number 20354015

The analog output for Catalog Number 20354015 is a 0-8 Vdc signal proportional to the logarithm of the pressure with 0 volts at 1×10^{-9} Torr. Figure 3-3 shows the pressures for Degas, 4 mA Emission, and 100 μ A Emission, where the overpressure shutdown occurs. With the 0-8 Vdc output the equation for pressure is:

$$\text{Pressure} = 10^{(\text{volts}-9)}$$

- When the Micro-Ion gauge is turned OFF, the output will switch to slightly over +10 Vdc.
- During an overpressure shutdown, the output will also switch to slightly over +10 Vdc.
- During degas, the overpressure shutdown occurs at 3×10^{-4} .
- At 4mA emission, the overpressure shutdown occurs at 1.5×10^{-3} .
- At 100 mA emission, the overpressure shutdown occurs at 5×10^{-2} .

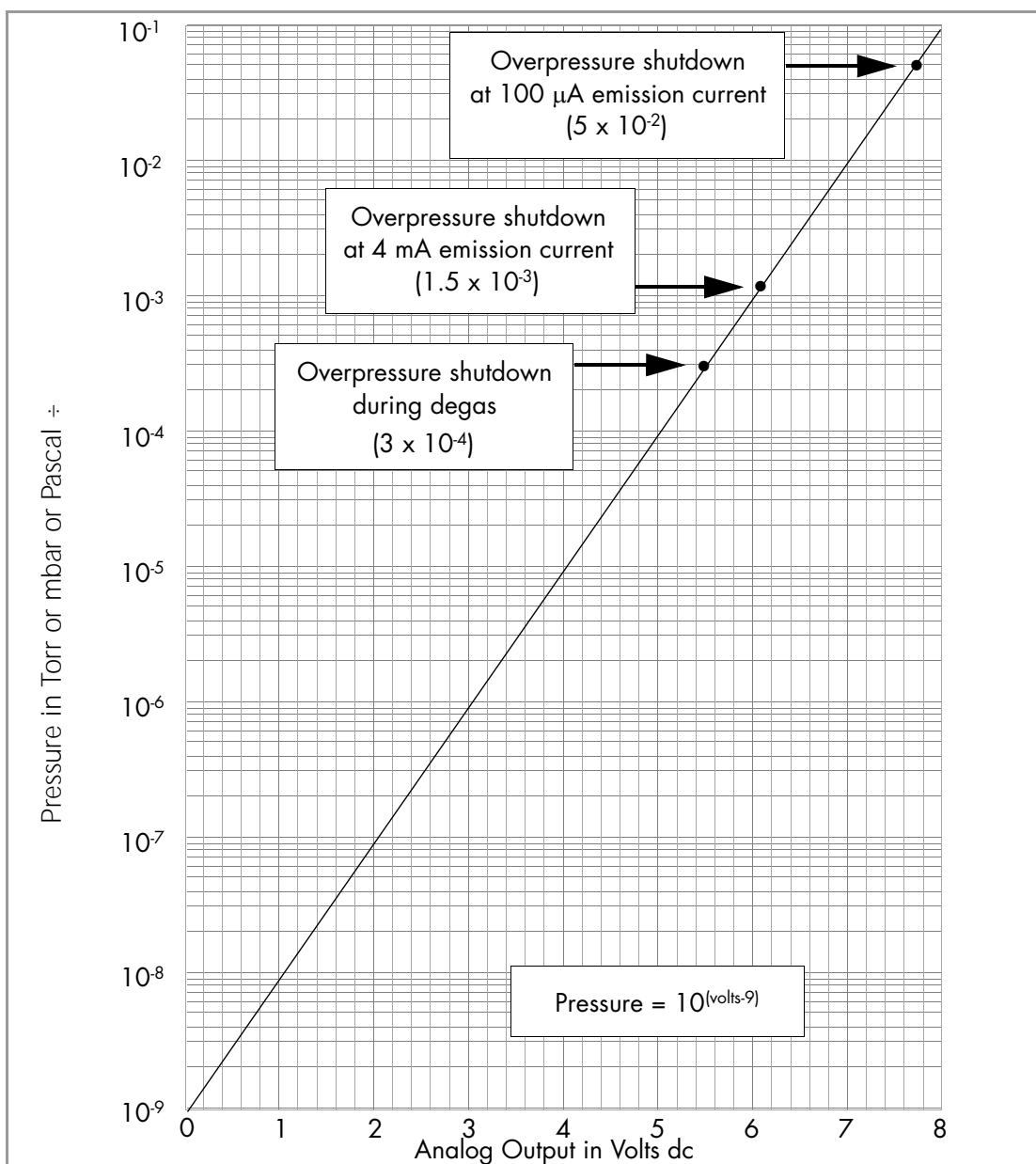

Figure 3-3 Analog Output Curve for Module 20354015.

3.5.2 Analog Output for Catalog Numbers 354019 and 20354014

The analog output for Catalog Numbers 354019 and 20354014 is a 0-9 Vdc signal proportional to the logarithm of the pressure with 0 volts at 1×10^{-11} Torr. Figure 3-4 shows the pressures for Degas, 4 mA Emission, and 100 μ A Emission, where the overpressure shutdown occurs. Additionally, the response time of the 20354014 has been reduced to meet a specific customer application. The equation for pressure is:

$$\text{Pressure} = 10^{(\text{volts}-11)}$$

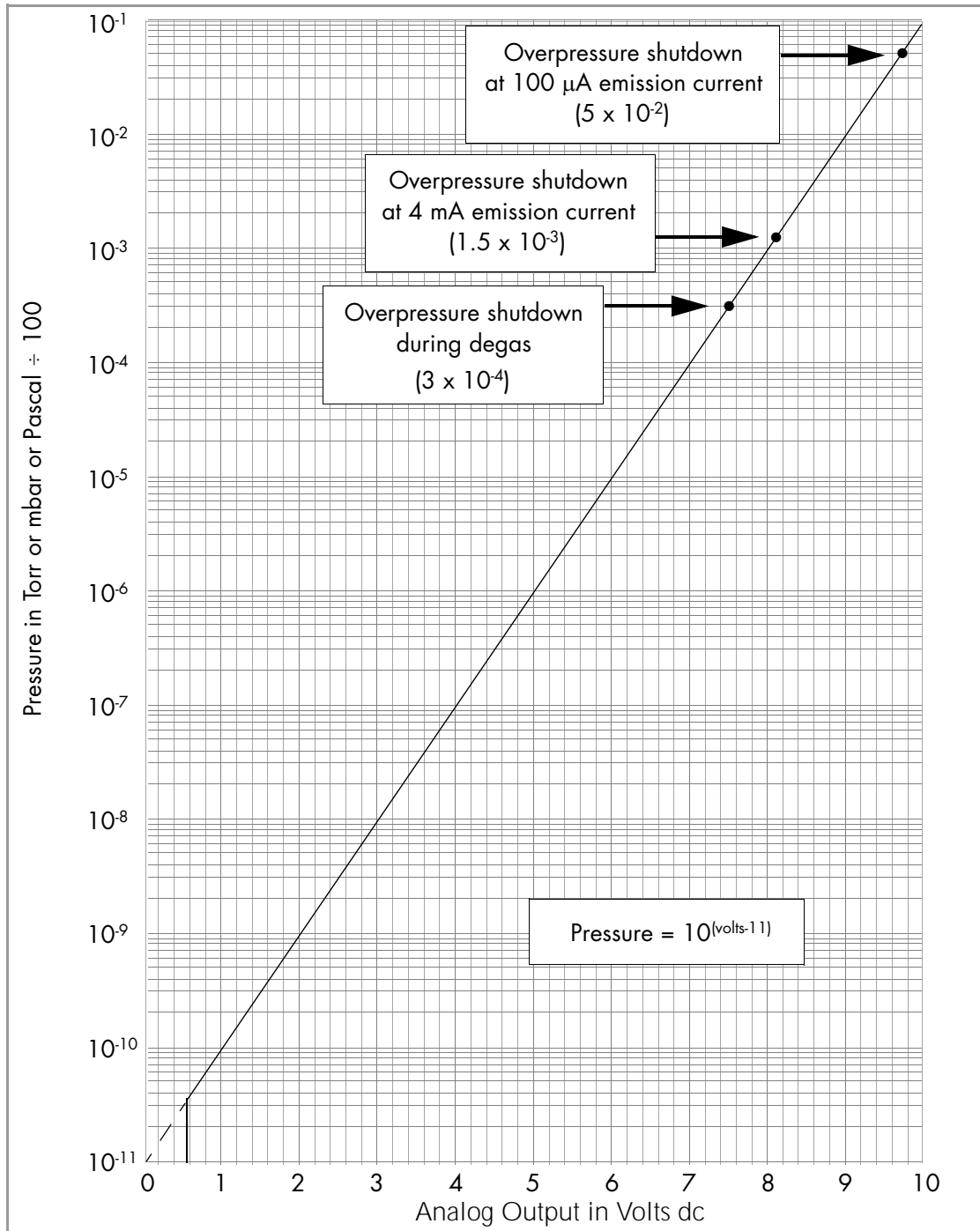

Figure 3-4 Analog Output Curve for Module 354019 and 20354014.

3.6 Gas Sensitivity Correction

The Micro-Ion Gauge Module is calibrated to read pressure for nitrogen or air. If used with gases other than this, it will be required that the analog output voltage to pressure reading be corrected for the gas in use. Table 3-3 gives some typical sensitivity ratios. To correct the analog output to pressure curve reading, divide the indicated pressure reading by the sensitivity ratio.

Ion gauge sensitivity ratios, r , derived from data obtained by NASA Technical Note TND5285, "Ionization Gauge Sensitivities as Reported in the Literature," by Robert L. Summers, Lewis Research Center, National Aeronautics and Space Administration are shown in Table 3-3.

Table 3-3 Ion Gauge Sensitivity Ratios (r).

Gas	He	Ne	D ₂	H ₂	N ₂	Air	O ₂	CO
r	0.18	0.30	0.35	0.46	1.00	1.00	1.01	1.05

Gas	H ₂ O	NO	Ar	CO ₂	Kr	SF ₆	Xe	Hg
r	1.12	1.16	1.29	1.42	1.94	2.50	2.87	3.64

3.6.1 Example

The analog output voltage is measured and found to be 5.80 Vdc which, for air or nitrogen, indicates a pressure of 5×10^{-5} Torr. If the gas type in the system is known to be neon, then

$$\frac{5 \times 10^{-5} \text{ Torr}}{0.30} = 1.67 \times 10^{-4} \text{ Torr of neon.}$$

3.7 Overpressure Shutdown

The Micro-Ion Gauge Module is preset by fixed component values to shut down the ion gauge should pressure rise above 5×10^{-2} Torr of nitrogen at 100 microamperes emission or 1.3×10^{-3} Torr of nitrogen at 4 milliamperes emission. Additionally, the response time of the 20354014 has been reduced to meet a specific customer application.

3.8 Very-High and Ultra-High Vacuum Measurement

For best results when measuring vacuum pressures below 1×10^{-7} Torr:

- Use only all-metal vacuum fittings.
- Degas the grid. See degas instructions following this section.
- A chamber bake to 100 to 150 °C is often required. When baking the chamber, be sure the temperature of the tube and the vacuum plumbing to the tube is raised at least as much as the chamber. The electronics module must be removed from the gauge if the bake-out temperature exceeds 70 °C. This can be done without breaking vacuum by removing the four screws securing the front plate to the aluminum extrusion enclosure. Pull the module away from the plate after the 4 screws are removed. The plate will stay attached to the tube (see Figure 4-1 on page 28). Do not exceed 200 °C.

After baking, re-install the electronics module by reversing the above procedure, being careful that the gauge pins line up with the sockets on the PC board.

3.9 Degas

Degassing of the gauge tube is accomplished by electron bombardment (EB) heating of the grid. Pressure reading during degas is provided. Note that in order to activate the degas circuit, the IG ON circuit must be first activated. This assures that there is a vacuum in the system prior to degas. Also note that the degas circuit will turn off if the IG ON circuit is turned off. Power during degas is approximately 4 watts above operating power and is turned off automatically after a two minute period.

3.9.1 Degas for Catalog Numbers 20354014 and 354019

For Catalog Numbers 20354014 and 354019, there are two user inputs to activate degassing of the ion gauge tube. The DEGAS button on the panel near the I/O connector can be used to manually activate degas or the I/O connector Pin 6 asserted low can be used to activate degas. The degas period is two minutes unless terminated sooner by another push of the button or I/O connector Pin 6 un-asserted. The DEGAS INDICATOR glows ORANGE during the degas cycle. Degas is disabled at pressures above 1×10^{-4} Torr.

3.10 Filament Selection

The Micro-Ion Gauge Module is equipped with a filament select switch adjacent to the I/O connector which allows the user to switch between the two filaments of the gauge tube. It is recommended that the gauge be turned off before switching to the other filament.

3.10.1 Filament Selection for Catalog Numbers 20354014 and 354019

Catalog Numbers 20354014 and 354019 are equipped with a FILAMENT SELECT switch near the I/O connector, which allows the user to switch between the two filaments of the gauge tube. If the switch is set to REMOTE, center position, filament selection will be determined by the I/O connector Pin 9. It is recommended that the gauge be turned off before switching filaments. This will prevent nuisance gauge shutdowns and premature wear of electrical contacts.

(See Table 2-2 on page 13, Pin 9 Gauge Status.)

3.11 Specifications for the Micro-Ion Gauge Module

Table 3-4 Specifications for the Micro-Ion Gauge Module.

Performance	
Measurement Range	1 x 10 ⁻⁹ to 5 x 10 ⁻² Torr for N ₂ or air. For use below 1 x 10 ⁻⁷ Torr the use of a Conflat flange or other type metal seal is recommended.
Analog Output	Logarithmic, 1 Vdc/decade.
Digital Display Update Rate	0.5 sec.
Overpressure Protection	Gauge tube turns off if pressure rises above 5 x 10 ⁻² Torr at 100 microamperes or 1.3 x 10 ⁻³ Torr at 4 milliampere emission.
Emission Current	2 ranges: 100 µA, 4 mA.
Operating Voltage & Power	+24 Vdc, ±15%, 12 watts max.
Degas	Electron bombardment, approximately 4 watts with 2 minute timer.
Physical	
Vacuum Connection	NW16KF flange, NW25KF flange, NW40KF flange, 1-5/16 in. Conflat, 2-3/4 in. Conflat or 1/2 in. 8-VCR male fitting.
Electrical Connection	9 pin "D" connector.
Filament Selection	2 position switch.
Weight	13 oz.
Case Material	Aluminum extrusion.
Gauge Tube Replacement	Field replaceable using only Phillips type screwdriver.
Electrical Safety	Metal enclosure which houses 180 V supply will require use of a metal flange clamp to assure ground continuity to system.
Operating Temperature Range	0 °C to 40 °C.
Non-operating Temperature Range	-40 °C to 70 °C.

NOTES

Chapter 4

Service and Maintenance

4.1 Service Guidelines

Some minor difficulties are readily corrected in the field.

Because the Micro-Ion Module contains static-sensitive electronic parts, the following precautions must be followed when troubleshooting:

- Use a grounded, conductive work surface. Wear a high impedance ground strap for personnel protection.
- Use conductive or static dissipative envelopes to store or ship static sensitive devices or printed circuit boards.
- Do not operate the product with static sensitive devices or other components removed from the product.
- Do not handle static sensitive devices more than absolutely necessary, and only when wearing a ground strap.
- Do not use an ohmmeter for troubleshooting MOS circuits. Rely on voltage measurements.
- Use a grounded, electrostatic discharge safe soldering iron.

NOTE: This product has been designed and tested to offer reasonably safe service provided it is installed, operated, and serviced in strict accordance with these safety instructions.



Danger, High Voltage – The high voltages present within the Power Supply are capable of causing injury or death. To avoid electric shock, wait 3 minutes after power is removed before touching any component within the Power Supply. This will permit charged capacitors to discharge.



The service and repair information in this manual is for the use of Qualified Service Personnel. To avoid shock, do not perform any procedures in this manual or perform any servicing on this product unless you are qualified to do so.



Do not substitute parts or modify instrument.

Because of the danger of introducing additional hazards, do not install substitute parts or perform any unauthorized modification to the product. Return the product to a service facility designated by Granville-Phillips for service and repair to ensure that safety features are maintained. Do not use this product if it has unauthorized modifications.

4.2 Damage Requiring Service

Disconnect this product from all power sources, and refer servicing to Qualified Service Personnel if any the following conditions exist:

- The gauge cable, power-supply cord, or plug is damaged.
- Liquid has been spilled onto, or objects have fallen into, the product.
- The product has been exposed to rain or water.
- The product does not operate normally even if you have followed the Operation Instructions. Adjust only those controls that are covered in the instruction manual. Improper adjustment of other controls may result in damage and require extensive work by a qualified technician to restore the product to its normal operation.
- The product has been dropped or the enclosure has been damaged.
- The product exhibits a distinct change in performance. This may indicate a need for service.



Replacement Parts - When replacement parts are required, be certain to use the replacement parts that are specified by Granville-Phillips, or that have the same characteristics as the original parts. Unauthorized substitutions may result in fire, electric shock or other hazards.



Safety Check - Upon completion of any service or repairs to this product, ask the Qualified Service Person to perform safety checks to determine that the product is in safe operating order.



Finite Lifetime - After ten years of normal use or even non-use, the electrical insulation in this product may become less effective at preventing electrical shock. Under certain environmental conditions which are beyond the manufacturer's control, some insulation material may deteriorate sooner. Therefore, periodically inspect all electrical insulation for cracks, crazing, or other signs of deterioration. Do not use if the electrical insulation has become unsafe.

4.3 Troubleshooting

Table 4-1 General Symptoms/Possible Causes.

Symptom	Possible Causes
Power indicator does not light.	<p>Power supply disconnected, off, or inadequate for load. A switching supply may shut down from the current surge upon power-up. If a switching power supply is used, size current limit to two times working load. See Table 3-4 on page 23 for power requirements.</p> <p>The connector may be wired wrong. See Section 2.5 I/O Cable Connections on page 13.</p> <p>Blown fuse. This could be caused by wrong wiring. Replace the fuse with the following fuse: 1 ampere, slow blow, 2AG, Granville-Phillips p/n 012084 (see Fuse Replacement on page 30).</p>
Ion gauge will not stay on.	<p>Overpressure condition. 50 milli Torr at 100 μA emission, 1.3 milli Torr at 4mA emission.</p> <p>Emission control failure. Causes include gauge failure due to broken filament, contamination, or pressure over 1 Torr.</p> <p>High voltage power to gauge failure. Causes include gauge failure due to mechanical damage or leakage due to contamination.</p>
Inaccurate pressure reading.	<p>Organic seals. If the ion gauge connection to the vacuum system is sealed with an organic O-ring, the gauge will not read accurately below 1e-7 Torr. Use a metal seal.</p> <p>Mechanical damage. If the unit is dropped or excessive force is applied to the vacuum connection during installation, gauge elements may be damaged or pin leaks may occur. Replace the ion gauge tube.</p> <p>Contamination. Pump oil and other organic compounds, or metal coating from a sputtering process can cause electrical current leakage between ion gauge elements. Degas the ion gauge by connecting Pin 6 (Degas On/Off) on the I/O connector to Pin 2 (Power Ground) (see Figure 2-2 on page 13). Degas will operate for up to two minutes. Disconnect Pin 6 from Pin 2 in order to allow another degas cycle.</p>

4.4 Ion Gauge Continuity Test



To prevent electrical shock, turn OFF electrical power before servicing the Micro-Ion Module. Do not touch any gauge pins while the gauge tube is under vacuum or connected to a controller.

This test should only be performed while the ion gauge is exposed to atmospheric pressure and the electronics is removed from the gauge. If a problem with pressure measurement is traced to the Micro-Ion Module, the gauge may be tested with an ohm meter. This test can detect open filaments or shorts between gauge elements. This test may not detect inaccurate pressure measurement due to gauge contamination or vacuum leaks.

1. Turn OFF power to the module.
2. Remove the I/O connector from the module.
3. Remove the Micro-Ion Module from the vacuum system.
4. Remove the four Phillips head screws from the gauge collar plate as shown in Figure 4-1.

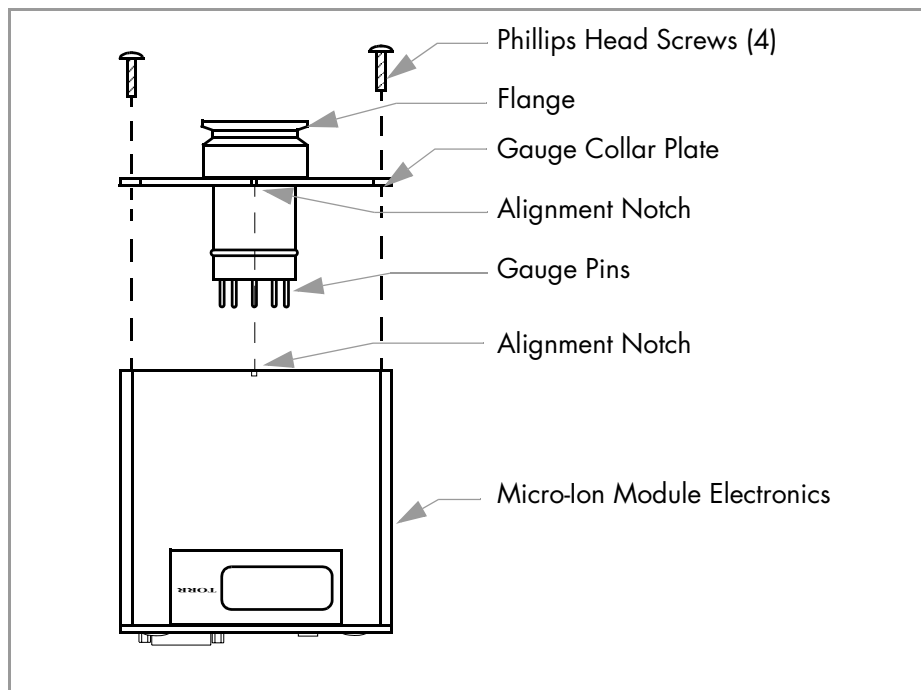

Figure 4-1 Micro-Ion Gauge Removal.

5. While holding the flange, **gently** pull the Micro-Ion Vacuum Gauge Module away from the gauge collar plate as shown in Figure 4-1. The gauge tube and plate will disconnect from the module.
6. Using a digital multimeter, measure the resistance of the left filament and the right filament between filament pins as shown in Figure 4-2 on page 29. The reading should be approximately 0.2Ω .

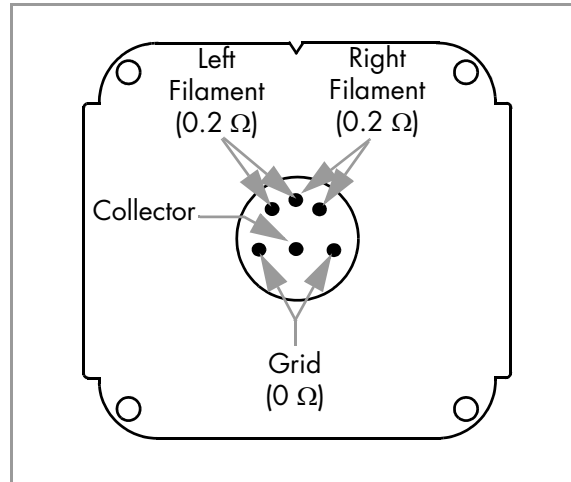

Figure 4-2 Micro-Ion Gauge Pin Identification.

7. Measure the resistance of filament pins to any other pin or gauge case as shown in Figure 4-2. The reading should be infinity.
8. Measure the resistance between Grid pins as shown in Figure 4-2. The reading should be approximately 0Ω .
9. Measure the resistance of Grid pins to any other pin or gauge case as shown in Figure 4-2. The reading should be infinity.
10. Measure the resistance of Collector pin to any other pin or gauge case as shown in Figure 4-2. The reading should be infinity.

NOTE: If the readings obtained during this procedure are not within the values specified, the gauge should be replaced. Contact a Brooks Automation, Inc./Granville-Phillips Customer Service Representative to order a replacement gauge.

11. Once the replacement Micro-Ion Gauge is received, refer to Section 4.6 Gauge Replacement on page 31 to install the gauge.

4.5 Fuse Replacement

Use the following procedure to replace the fuse in the Micro-Ion module.



To prevent electrical shock, turn OFF electrical power before servicing the Micro-Ion Module.

1. Turn OFF power to the Micro-Ion Module.
2. Disconnect the I/O cable from the connector.
3. Remove the I/O cable connector jack posts from the connector.
4. Remove the four screws from the Micro-Ion Module top cover and remove the cover.
5. Locate the defective fuse as shown in Figure 4-3 and replace it with a new 1 amp, slow blow fuse.

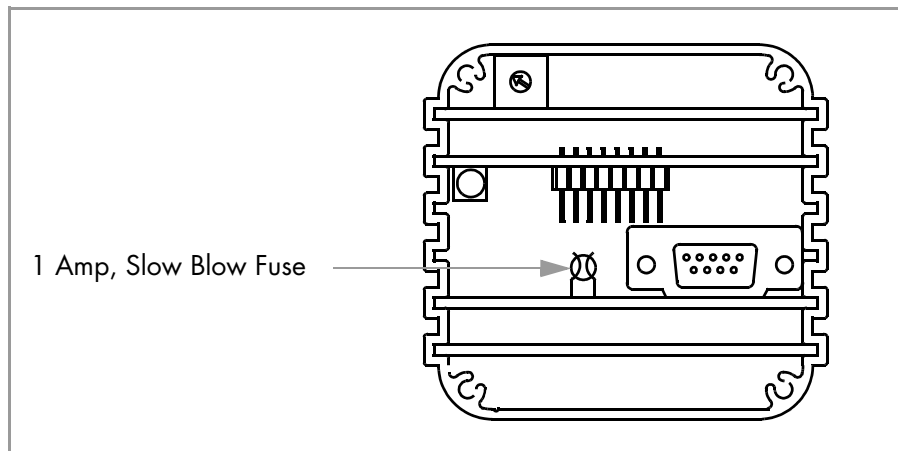

Figure 4-3 Position of 1 Amp, Slow Blow Fuse.

6. Install the Micro-Ion Module top cover with the previously removed four screws.
7. Install the I/O cable connector jack posts on the connector.
8. Connect the I/O cable to the connector.
9. Turn ON power to the Micro-Ion Module. It is now ready to be used.

4.6 Gauge Replacement

The Micro-Ion Module replacement gauge is double-packaged at the factory for cleanroom compatibility. Handle the gauge carefully to avoid damaging the vacuum port screen after the cap plug is removed. To reduce the chance of contamination, do not remove a Micro-Ion Module replacement gauge from its inner bag until moments before it is to be connected to the module and vacuum system.

Avoid contaminating the Micro-Ion Module replacement gauge. Do not touch the vacuum connection port. Follow good vacuum practice. To minimize the possibility of leaks, do not scratch the vacuum connection seal surfaces.

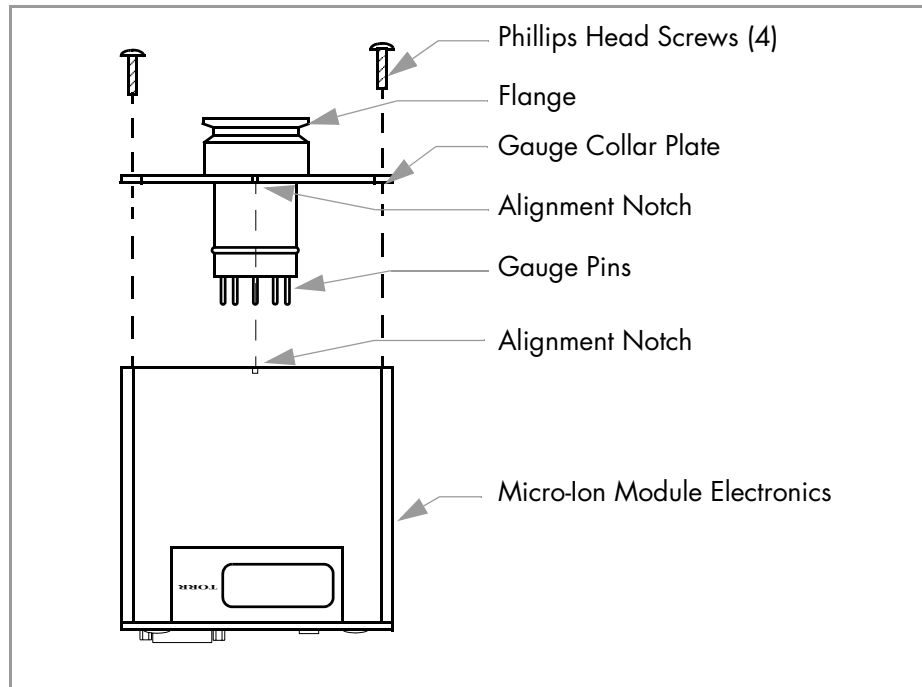

Figure 4-4 Micro-Ion Gauge Removal.

Use the following step-by-step procedure to replace the Micro-Ion Module gauge:

1. Turn off power to the Micro-Ion Module and unplug the electrical connector.
2. Remove the Micro-Ion Module from the vacuum system.
3. Remove the four Phillips head screws from the plate that attaches the gauge to the module.
4. Gently pull (unplug) the gauge from the module.
5. Insert the replacement gauge in the module by aligning the notch on the replacement gauge plate with the notch in the module body. Gently insert the gauge by engaging the pins into the socket on the module circuit board.
6. Replace the four Phillips head screws and tighten.
7. Reinstall the Micro-Ion Module on the vacuum system.
8. Plug in the electrical connector and restore power to the module.



Be aware that an electrical discharge through a gas may couple dangerous high voltage directly to an ungrounded conductor almost as effectively as would a copper wire connection. A person may be seriously injured or even killed by merely touching an exposed ungrounded conductor at high potential. This hazard is not peculiar to this product.



All conductors in, on, or around the vacuum system that are exposed to potential high voltage electrical discharges must be shielded at all times to protect personnel or must be connected to earth ground at all times. Verify that the vacuum port to which the Micro-Ion Gauge is mounted is electrically grounded. It is essential for personnel safety as well as proper operation that the envelope of the gauge be connected to a facility ground. Use a ground lug on a flange bolt if necessary.

Do not touch the Micro-Ion Gauge during degas operation. Burns can occur.



Return policy – The Micro-Ion Gauge cannot be returned to Granville-Phillips for credit if the inner bag seal is broken.

4.7 Returning a Micro-Ion Module for Service

Some minor problems are readily corrected on site. If the product requires service, please contact our Customer Service Department at 303-652-4400 for troubleshooting help over the phone.

If the module must be returned to the factory for service, request a Return Authorization (RA) from Brooks Automation / Granville-Phillips. Do not return products without first obtaining an RA. In some cases a hazardous materials document may be required. The Brooks Automation / Granville-Phillips Customer Service Representative will advise you if the hazardous materials document is required.

When returning equipment to Brooks Automation / Granville-Phillips, be sure to package the products to prevent shipping damage. Circuit boards and modules separated from the controller chassis must be handled using proper anti-static protection methods and must be packaged in anti-static packaging. Brooks Automation / Granville-Phillips will supply return packaging materials at no charge upon request. Shipping damage on returned products as a result of inadequate packaging is the Buyer's responsibility. **Before you return the module**, obtain an RA number by contacting Granville-Phillips customer service:

- Phone **1-303-652-4400** or **1-800-776-6543** within the USA.
- Phone **1-800-367-4887** 24 hours per day, seven days per week within the USA.
- Email **co-csr@brooks.com**
- For Global Customer Support, go to www.brooks.com, click on Contact Us, then click on Global Offices to locate the Brooks Automation office nearest you.

Index

A

Ambient temperature 11
 Analog connector 13
 Analog output 17, 19, 20, 23
 Analog output ground pin 13
 Analog output pin 13

C

Calibration gases 21
 Case material 23
 Clamp 12
 Connections, I/O cable 13
 Connector, analog pins 13
 Current, emission 16

D

Damage requiring service 26
 safety 8
 Degas 22, 23
 Degas ON/OFF pin 13
 Degas status pin 13
 Digital display update rate 23
 Dimensions 11

E

Electrical connection 23
 Electrical safety 23
 Emission current 16, 23
 Emission current pin 13

F

FCC verification 10
 Filament select switch 13, 22, 23
 Fittings 12
 Fuse replacement 30

G

Gas sensitivity correction 21
 Gauge dimensions 11
 Gauge ON/OFF 15
 Gauge On/Off pin 13
 Gauge replacement 31, 32
 Gauge status pin 13
 Gauge tube replacement 23, 31
 Ground test 9
 Grounding 12

I

I/O cable connections 13
 I/O connector pin descriptions 13
 Inaccurate pressure reading 27
 Input power 12
 Input power pin 13
 Installation 11
 Ion gauge
 continuity test 28
 sensitivity ratios (r) 21
 Ion gauge will not stay on 27

L

LED states 16

M

Measurement range 23
 Mounting 11

N

Non-operating temperature range 23

O

Operating temperature range 23
 Operating voltage and power 23
 Operation 15
 Overpressure
 protection 23
 shutdown 21

P

Performance specifications 23
 Physical specifications 23
 Pins, analog connector 13
 Power ground pin 13
 Power indicator
 does not light 27
 LED states 16
 Power, operating 23

S

Safety 7
 damage requiring service 8
 electrical 23

grounding to vacuum chamber 12

instructions 7
 Schematic for ion gauge 15
 Sensitivity ratios (r) 21
 Service guidelines 10, 25
 Shutdown, overpressure 21
 Specifications 23
 System ground 9

T

Temperature
 non-operating range 23
 of mounting location 11
 operating range 23
 Test, ion gauge continuity 28
 Theory of operation 15
 Troubleshooting 27

V

Vacuum connection 23
 Vacuum measurement, very-high and ultra-high 21
 Very-high and ultra-high vacuum measurement 21
 Voltage, operating 23

W

Warranty 10
 Weight 23

Series 354

Granville-Phillips Series 354 Micro-Ion® Vacuum Gauge Module with Analog Output



6450 Dry Creek Parkway

Longmont, CO USA 80503
Phone: 1-303-652-4400

15 Elizabeth Drive

Chelmsford, MA USA 01824
Phone: 1-978-262-2400

Worldwide Customer Service/Support - 24/7
Phone: 1-800-367-4887

To obtain a copy of this instruction manual online,
visit our website at www.brooks.com

(Adobe® Reader® version 5.0 or higher required)

© 2006-2008, Brooks Automation, Inc.

Instruction Manual

Instruction manual part number 354004

Revision 05 - January 2008