

SERIES 347
VACUUM GAUGE
MODULE

INSTRUCTION MANUAL

GRANVILLE-PHILLIPS
HELIX TECHNOLOGY CORPORATION

**347 VACUUM GAUGE MODULE
INSTRUCTION MANUAL**

READ AND UNDERSTAND THE CONTENTS OF THIS MANUAL BEFORE ATTEMPTING TO INSTALL OR USE YOUR SERIES 347 VACUUM GAUGE MODULE.

THIS MANUAL IS FOR USE ONLY WITH THE FOLLOWING CONTROLLER CATALOG NUMBERS:

**20347008,20347012,
347008,347012
347054-YE-T,347054-YU-T**

For assistance in using or servicing this instrument contact:

**GRANVILLE-PHILLIPS CUSTOMER SERVICE DEPARTMENT
6450 DRYCREEK PARKWAY
LONGMONT, COLORADO 80503 U. S. A**

**TELEPHONE (303) 652-4400
FAX (303) 652-4484**

SEE WARNINGS ON PAGES 0.3, 0.4, 1.2

Manual Catalog No. 347011 Rev. 0
©Granville-Phillips Co., October 2003

SEE WARNINGS ON NEXT 2 PAGES

RECEIVING INSPECTION

On receipt of your equipment, inspect all material for damage. Confirm that the shipment includes all items ordered. If items are missing or damaged, submit a claim as stated below for a domestic or international shipment, whichever is applicable.

If materials are missing or damaged, the carrier that made the delivery must be notified within 15 days of delivery, or in accordance with Interstate Commerce regulations for the filing of a claim. Any damaged material including all containers and packaging should be held for carrier inspection. Contact our Customer Service Department, 6450 Dry Creek Parkway, Longmont, Colorado 80503, telephone (303) 652-4400, if your shipment is not correct for reasons other than shipping damage.

INTERNATIONAL SHIPMENT

Inspect all materials received for shipping damage and confirm that the shipment includes all items ordered. If items are missing or damaged, the airfreight forwarder or airline making delivery to the customs broker must be notified within 15 days of delivery. The following illustrates to whom the claim is to be directed.

- If an airfreight forwarder handles the shipment and their agent delivers the shipment to customs, the claim must be filed with the airfreight forwarder.
- If an airfreight forwarder delivers the shipment to a specific airline and the airline delivers the shipment to customs, the claim must be filed with the airline.

Any damaged material including all containers and packaging should be held for carrier inspection. If your shipment is not correct for reasons other than shipping damage, contact our Customer Service Department, 6450 Dry Creek Parkway, Longmont, Colorado 80503, telephone (303) 652-4400.

WARNING

READ THIS INSTRUCTION MANUAL BEFORE INSTALLATION, USING, OR SERVICING THIS EQUIPMENT. IF YOU HAVE ANY DOUBTS ABOUT HOW TO USE THIS EQUIPMENT SAFELY, CONTACT THE GRANVILLE-PHILLIPS CUSTOMER SERVICE DEPARTMENT AT THE ADDRESS LISTED ON THIS MANUAL.

DANGER, HIGH VOLTAGE

Voltages (up to 180 Vdc) capable of causing injury or death are present in the power supply. Avoid touching the connector sockets, tube pins, and other high voltage conductors. Servicing should be performed by qualified personnel only.

DANGER, EXPLOSIVE GASES

Do not turn on the ionization gauge when there is danger of explosion from explosive or combustible gases, or gas mixtures. Ionization gauge filaments operate at temperatures sufficiently high to cause ignition.

IMPLOSION AND EXPLOSION

Danger of injury to personnel and damage to equipment exists on all vacuum systems that incorporate gas sources or involve processes capable of pressurizing the system above the limits it can safely withstand.

For example, danger of explosion in a vacuum system exists during backfilling from pressurized gas cylinders because many vacuum devices such as ionization gauge tubes, glass windows, glass bell jars, etc., are not designed to be pressurized.

Install suitable devices that will limit the pressure from external gas sources to the level that the vacuum system can safely withstand. In addition, install suitable pressure relief valves or rupture discs that will release pressure at a level considerably below that pressure which the system can safely withstand.

Suppliers of pressure relief valves and pressure relief discs are listed in Thomas Register under "Valves, Relief", and "Discs, Rupture".

Confirm that these safety devices are properly installed before installing the Mini-Ion Gauge. In addition, check that (1) the proper gas cylinders are installed, (2) gas cylinder valve positions are correct on manual systems, and (3) the automation is correct on automated systems.

WARNING

Safe operation of ion producing equipment, including the 347 Vacuum Gauge Module, requires grounding of both its power supply and the vacuum chamber. **LETHAL VOLTAGES** may be established under some operating conditions unless correct grounding is provided.

Research at Granville-Phillips has established that ion producing equipment, such as ionization gauges, mass spectrometers, sputtering systems, etc., from many manufacturers may, under some conditions, provide sufficient conduction via a plasma to couple a high voltage electrode to the vacuum chamber. If conductive parts of the chamber are not grounded, they may attain a potential near that of the high voltage electrode during this coupling.

Potentially fatal electrical shock could then occur because of the high voltage between these chamber parts and ground.

During routine pressure measurement, using ionization gauge controllers from any manufacturer, about 160 V may become present on ungrounded chambers at pressures near 10^{-3} Torr. All isolated or insulated conductive parts of the chamber must be grounded to prevent these voltages from occurring.

Grounding, though simple, is very important! Please be certain that the ground circuits are correctly utilized, both on your ion gauge power supplies and on your vacuum chambers, regardless of their manufacturer, for this phenomenon is not peculiar to Granville-Phillips equipment. Refer to Safety Instructions and Section 1.2, Installation, for additional information. If you have questions, or wish additional labels or literature, please contact one of our service personnel.

CHAPTER 1 - THE 347 VACUUM GAUGE MODULE

1.1 INTRODUCTION

General Description

The 347 Vacuum Gauge Module, in conjunction with a Series 360 *Stabil-Ion*[®] Gauge Tube measures pressures from 1×10^{-10} Torr to 2×10^{-2} Torr, air equivalent.

An analog output voltage proportional to the common logarithm of pressure is available on pins 3 and 7 of the I/O connector.

The 347 vacuum gauge module is intended for computer control only with no external controls or adjustments. The power supply voltage required for operation is 24 Vdc, 70 watts.

1.2 INSTALLATION

Gauge Installation Tips

For best results locate pressure gauges close to the point where pressure is to be measured. Gas sources, long tubulation or other constrictions can cause large errors in indication. Note that if placed near the pump, the pressure in the gauge may be considerably lower than in the rest of the system. If placed near a gas inlet or source of contamination, the pressure in the gauge may be much higher.

To minimize temperature effects, locate pressure gauges away from internal and external heat sources in a region where the ambient temperature is reasonably constant.

Parts of the gauge can get quite hot during degassing, especially if there is poor ventilation. This will not damage the gauge. However, care should be taken to prevent low temperature rated materials such as plastic wire insulation from touching hot parts of the gauge.

Stabil-Ion Gauge Installation

Verify that the vacuum port to which the *Stabil-Ion* Gauge is mounted is electrically grounded. It is essential for personnel safety as well as proper operation that the envelope of the gauge be connected to a facility ground. Use a ground lug on a flange bolt if necessary.

1. The *Stabil-Ion* Gauge is double packaged at the factory for cleanroom compatibility. To reduce the chance of contamination, do not remove a *Stabil-Ion* Gauge from its inner bag until moments before it is to be connected to the vacuum system.

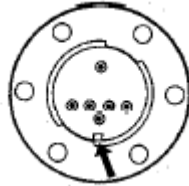

Fig. 1.1 *Stabil-Ion* Gauge showing connector locating key.

2. Any mounting orientation may be used. However, to minimize the possibility of excessive temperature at the electrical connector when degassing, it is best to not install the *Stabil-Ion* Gauges with the electrical connector above the gauge. If it is necessary to install the gauge with the connector on top, degas time must be limited to 10 minutes/hour. When mounting horizontally, the ventilation slots in the Guard will be oriented for best cooling if the gauge is installed with the locating key in the pin guard on the bottom. See Fig. 1.1.
3. Avoid contaminating the *Stabil-Ion* Gauge. Do not touch the port. Do not talk directly at an open vacuum port. Follow good vacuum practice.
4. To minimize the possibility of leaks with ConFlat¹ flanges, use high strength stainless steel bolts and a new, clean OFHC copper gasket. Avoid scratching the seal surfaces. Do not use nonmetal gaskets.
5. After finger tightening all bolts, continue tightening about 1/8 turn in crisscross order, e.g., 1, 4, 2, 5, 3, 6, 4, 1, 5, 2, 6, 3, 1.....until the flanges are in contact. After contact, further tighten each bolt about 1/16 turn.

General

The 347 Vacuum Gauge Module is mechanically attached to the gauge tube by use of the gauge tube connector. The location on the system should have free air flow and an ambient temperature less than 40 °C.

¹ConFlat is a registered Trademark of Varian Associates

CAUTION

The 20347008,347008, and 347054-YE-T are configured to operate the standard extended range *Stabil-Ion* Gauge Catalog No. 360120. Use the 20347012,347012, or 347054-YU-T when operating the UHV *Stabil-Ion* Gauge Catalog No. 360121. Failure to use the correct module for the *Stabil-Ion* Gauge being used will result in inaccurate pressure measurements.

347 Mounting Configuration

The 347 Vacuum Gauge Module is mounted to the gauge tube by the connector with locking ring attached. Line up the notch of the connector with the locating key of the pin guard and gently push down on the module. Rotate the locking ring to secure the module in place. Reasonable care should be taken to install the gauge tube and module where it will be protected from physical damage.

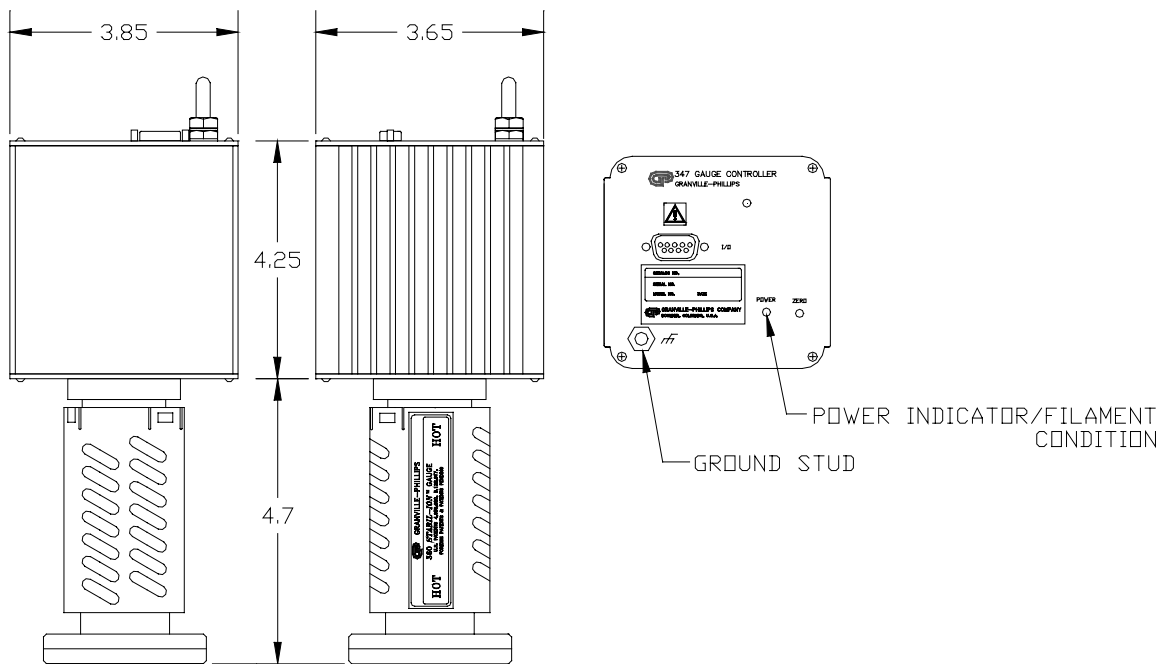

Fig. 1.2 347 Outline Drawing

Grounding

The 347 Vacuum Gauge Module converts the 24 Vdc input power to +180 Vdc for the grid supply during normal operation and +550 Vdc during degas. While none of the internal circuitry is directly connected to the outer housing, it must be grounded to the vacuum chamber to allow for the remote possibility of a grid circuit component contacting the case and resulting in a safety hazard. A ground stud has been provided for this purpose. It is necessary that an 18 gauge or heavier wire be connected between this stud and system ground.

I/O Cable Connections

The I/O connector is used to operate the 347 module and output the analog voltage corresponding to pressure.

Pin Function

- 1 GAUGE ON/OFF. The application of a continuous ground is required for an "ON" condition. Removal of the ground turns the gauge off.
- 2 Power Ground. Use for input power return, IG ON/OFF, Degas ON/OFF, and status outputs.

- 3 Analog Output signal (1 V/decade).
- 4 Input Power. +24 Vdc \pm 15%, 70 watts max. Protected against reversal and overvoltage.
- 5 Degas Status. Open collector transistor (grounded emitter) rated at 40 V max VCE, 55 mA max. Transistor off = degas off, transistor on = degas on.
- 6 Degas ON/OFF. Same as Gauge ON/OFF.
- 7 Signal Ground. Use in conjunction with the analog output only.
- 8 Emission Current. Application of a ground increases emission current from 100 micro amperes to 4 milliamperes.
- 9 Gauge Status. Same as Degas Status, except transistor collector current is 50 mA max.

1.3 OPERATION

Theory of Operation

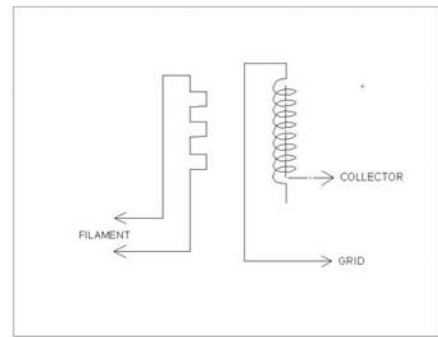

Fig. 1.3 Ion Gauge

The functional parts of a typical ionization gauge are the filament (cathode), grid (anode) and ion collector, which are shown schematically in Fig. 1.3. These electrodes are maintained by the gauge controller at +30, +180, and 0 volts, relative to ground, respectively.

The filament is heated to such a temperature that electrons are emitted, and accelerated toward the grid by the potential difference between the grid and filament. Most of the electrons eventually collide with the grid, but many first traverse the region inside the grid one or more times.

When an energetic electron collides with a gas molecule an electron may be dislodged from the molecule leaving it with a positive charge. Most ions are then accelerated to the collector. The rate at which electron collisions with molecules occur is proportional to the density of gas molecules, and hence the ion current is proportional to the gas density (or pressure, at constant temperature).

The amount of ion current for a given emission current and pressure depends on the ion gauge design. This gives rise to the definition of ion gauge "sensitivity", frequently denoted by "K":

$$K = \text{ion current}/(\text{emission current} \times \text{pressure})$$

Sensitivity

The extended range 360 gauge has a sensitivity of 45/Torr and the UHV 360 gauge has a sensitivity of 20/Torr when used with nitrogen or air. The 20347008, 347008, and 347054-YE-T are set for use with the 360120 (45/Torr) and the 20347012, 347012 and 347054-YU-T are set for use with the 360121 (20/Torr).

The ion gauge controller varies the heating current to the filament to maintain a constant electron emission, and measures the ion current to the collector. The pressure is then calculated from these data.

Emission Current

There are two ranges of emission current available. Either 100 microamps or 4 milliamps is available as determined by the status of pin 8 of the I/O connector. While either range can be used continuously, the following guidelines are suggested. For operation in the higher pressure ranges with a clean system 100 microamperes emission is satisfactory. Operating with a lower emission current generally results in longer filament life due to decreased interaction of energetic species and the filament. The pressure measurement range is extended with the use of lower emission current which allows the pressure reading to overlap with other type transducers such as the *CONVECTRON* or Capacitance Manometer. For operation in the lower pressure ranges, the 4 milliamperes range can be used to give a more accurate pressure reading. Internal circuitry corrects the analog output voltage to pressure relationship curve for the emission current selected.

There is a problem with all ion gauges when used in systems which have the potential for diffusion pump oil vapor to enter the gauge tube. This oil vapor deposits on the grid forming an insulator and preventing emission resulting in higher and higher filament power being required and ultimate inability to control emission. In this situation the 4 milliamp position is recommended.

360 Filament Switching

The 347 module will automatically switch filaments on the 360 gauge if one of the two is not operable. Whenever 24 V power is applied, the 347 will always attempt to establish emission current with BOTH filaments. If emission current is not established with both filaments within 5 seconds, the 347 will automatically switch to single filament operation.

This is the sequence of filament switching:

Turn on both filaments. If no emission after 5 seconds, turn on only filament 1. If no emission after 5 seconds, turn on both filaments. If no emission after 5 seconds, turn on only filament 2.

Notice the 5 second time delay required for filament switching. Once a good combination is found and emission is established, every time the 360 is turned on the combination that last worked will be used. This will eliminate any time delay for subsequent 360 on/off cycles. Note that if a filament is burned out, there will always be a delay in operation of the ion gauge after 24 V power is cycled.

The Power LED Indicator will illuminate green when power is applied and both filaments are operating. If the 347 is operating only one filament of the 360 *STABIL-ION* Gauge, the Power Indicator will glow orange in color.

Analog Output

This signal is proportional to the logarithm of the pressure (1 V/decade) with 0 volts at 1×10^{-10} Torr. When the IG is turned off the output will switch to slightly over + 10 Vdc. Refer to Fig. 1.3 for complete details.

Gas Sensitivity Correction

The 347 module is calibrated to read pressure for nitrogen or air. If used with gases other than this, it will be required that the analog output voltage to pressure reading be corrected for the gas in use. Table 1.1 gives some typical sensitivity ratios. To correct the analog output to pressure curve reading, divide the indicated pressure reading by the sensitivity ratio.

Table 1.1

Ion gauge sensitivity ratios, r, derived from data obtained by S. Dushman and A. H. Young, Phys, Rev. 68 278 (1945).

Gas	N ₂	H _e	N _e	A _r	K _r	X _e	H ₂
r	1	0.15	0.24	1.19	1.86	2.73	0.46

Example

The analog output voltage is measured and found to be 4.69 Vdc which, for air or nitrogen, indicated a pressure of 5×10^{-5} Torr. If it is known that the gas type in the system is neon then

$$\frac{5 \times 10^{-5} \text{ Torr}}{.24} - 2.08 \times 10^{-4} \text{ Torr of neon}$$

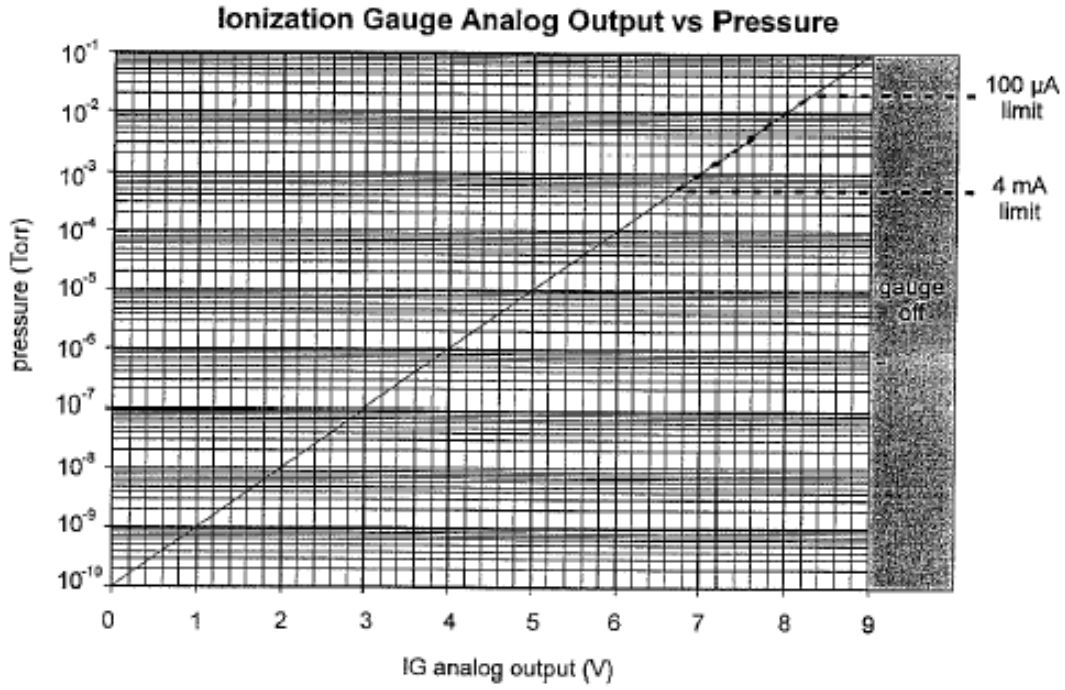

Fig. 1.4 IG Analog Output (V), $P = 10^{V-10}$

Overpressure Shutdown

The 347 is preset by fixed component values to shut down the ion gauge should pressure rise above 2×10^{-2} Torr of nitrogen when operating at .1 mA emission current and 5×10^{-4} Torr at 4 mA emission current.

Gauge ON/OFF

To turn the gauge on it is required that pin 1 be grounded to pin 2 of the I/O connector. To turn the gauge off, remove the ground. Note that the application of the ground will only try to turn the gauge on once. If, for any reason, this is not successful, it will be required that the input be recycled back to off and then on again.

Possible reasons for this to happen include:

1. Initial application of power to the unit.
2. Attempt made to turn on the gauge at a pressure where emission could not be established.
3. An overpressure shutdown where system pressure exceeded the overpressure shutdown level.

Degas

Degassing of the gauge tube is accomplished by Electron Bombardment heating of the grid. Note that in order to activate the degas circuit, the IG ON circuit must be first activated. This assures that there is a vacuum in the system prior to degas. Also note that the degas circuit will turn off if the IG ON circuit is turned off. Power during degas is approximately 20 watts above operating power and is turned off automatically after a two minute time period.

SPECIFICATIONS FOR 347 CONTROLLER

PERFORMANCE

Measurement Range:	1×10^{-10} to 2×10^{-2} Torr for N ₂ .
Analog Output:	Logarithmic, 1 Vdc/decade.
Overpressure Protection:	Gauge tube turns off if pressure rises above 2×10^{-2} Torr when emission current is .1 mA. Gauge tube turns off if pressure rises above 5×10^{-4} Torr when emission current is 4 mA.
Emission Current:	2 ranges: 0.1 mA, 4 mA.
Degas:	Electron bombardment, approximately 20 watts with 2 minute timer.

PHYSICAL

Vacuum Connection:	2-3/4 inch Conflat.
Electrical Connection:	9 pin "D" connector.
Weight: tube).	1 lb., 10 oz. (not including ion gauge tube).
Case Material:	Aluminum extrusion.
Gauge Design:	360 <i>Stabil-Ion</i> gauge.
Gauge Tube Replacement:	Field replaceable using connector ring.
Electrical Safety:	Metal enclosure which houses 500 V supply will require use of a ground wire to assure ground continuity to system.
Operating Temp Range:	0 °C to 40 °C.
Non-operating Temp Range:	-40 °C to 70 °C.