

SERIES 275

**DIGITAL DISPLAY MINI-CONVECTRON
VACUUM GAUGES**

WITH

**ANALOG OUTPUT
AND DUAL PROCESS RELAY OPTION**

INSTRUCTION MANUAL

GRANVILLE-PHILLIPS
HELIX TECHNOLOGY CORPORATION

**INSTRUCTION MANUAL
SERIES 275
DIGITAL DISPLAY MINI-CONVECTRON
VACUUM GAUGES
WITH ANALOG OUTPUT AND DUAL PROCESS RELAY OPTION**

**YOU SHOULD READ THIS INSTRUCTION MANUAL BEFORE
INSTALLING, USING, OR SERVICING THIS EQUIPMENT**

This manual is for use only with Series 275 Mini-CONVECTRON Vacuum Gauges with the following part numbers:

275904	275905	275906	275907
275908	275909	275910	275911
275912	275913	275914	275915
275916	275917	275918	275919
275920	275921	275922	275923
275924	275925		

CERTIFICATION

Granville-Phillips certifies that this product met its published specifications at the time of shipment from the factory.

LIMITED WARRANTY

This Granville-Phillips product is warranted against defects in materials and workmanship for one year from the date of shipment provided the installation, operating and preventive maintenance procedures specified in this instruction manual have been followed. Granville-Phillips will, at its option, repair, replace or refund the selling price of the product if Granville-Phillips determines, in good faith, that it is defective in materials or workmanship during the warranty period, provided the item is returned to Granville-Phillips together with a written statement of the problem.

Defects resulting from or repairs necessitated by misuse or alteration of the product or any cause other than defective materials or workmanship are not covered by this warranty. GRANVILLE-PHILLIPS EXPRESSLY DISCLAIMS ANY OTHER WARRANTY, WHETHER EXPRESSED OR IMPLIED, INCLUDING BUT NOT LIMITED TO THE IMPLIED WARRANTIES OF MERCHANTABILITY AND FITNESS FOR A PARTICULAR PURPOSE. UNDER NO CIRCUMSTANCES SHALL GRANVILLE-PHILLIPS BE LIABLE FOR CONSEQUENTIAL OR OTHER DAMAGES RESULTING FROM A BREACH OF THIS LIMITED WARRANTY OR OTHERWISE.

Instruction Manual 275892
Granville-Phillips
5675 Arapahoe Ave.
Boulder, CO 80303
(303) 443-7660, Fax (303) 443-2546
Revised April 2000

CONTENTS

MODELS COVERED AND WARRANTY

SPECIFICATIONS

SECTION 1	SAFETY INSTRUCTIONS, SPECIFICATIONS
SECTION 2	INSTALLATION INSTRUCTIONS
SECTION 3	OPERATING INSTRUCTIONS
SECTION 4	CALIBRATION
SECTION 5	USE WITH GASES OTHER THAN N ₂ OR AIR
SECTION 6	MAINTENANCE AND TROUBLESHOOTING

WARNING

Danger of injury to personnel and damage to equipment exists on all vacuum systems that incorporate gas sources or involve processes capable of pressurizing the system above the limits it can safely withstand.

For example, danger of explosion in a vacuum system exists during backfilling from pressurized gas cylinders because many vacuum devices such as ionization gauge tubes, glass windows, glass bell jars, etc., are not designed to be pressurized.

Install suitable devices that will limit the pressure from external gas sources to the level that the vacuum system can safely withstand. In addition, install suitable pressure relief valves or rupture discs that will release pressure at a level considerably below that pressure which the system can safely withstand.

Suppliers of pressure relief valves and pressure relief discs are listed in Thomas Register under the respective headings "Valves, Relief: and Discs, Rupture".

WARNING

275 *CONVECTRON* gauges are intended for use only on vacuum systems which have suitable devices installed that will limit the pressure from external gas sources to the level the system can safely withstand and which also have suitable pressure relief valves or rupture discs installed. Confirm that these safety devices are properly installed before installing the *CONVECTRON* gauge. In addition, check that (1) the proper gas cylinders are installed, (2) gas cylinder valve positions are correct on manual systems, and (3) the automation is correct on automated systems.

SAFETY WARNING

CONCERNING INSTALLATION OF VACUUM COMPONENTS



All conductors in, on, or around a vacuum system that are exposed to potential high voltage electrical discharges must either be shielded so as to prevent human contact, or be connected to earth ground for safe operation.



When high voltage is present in any vacuum system, a life threatening electrical shock hazard may exist unless all exposed conductors are maintained at earth ground. However, grounding this product does not guarantee that other components of the vacuum system are maintained at earth ground.

This hazard is not peculiar to this product.



Be aware that an electrical discharge through a gas may couple dangerous high voltage directly to an ungrounded conductor almost as effectively as would a copper wire connection. A person may be seriously injured or even killed by merely touching an exposed ungrounded conductor at high potential.

This hazard is not peculiar to this product.

Under certain conditions, dangerous high voltage can be coupled directly to an ungrounded conductor through a gas almost as effectively as through a copper wire connection. This hazard, which is not peculiar to this product, is a consequence of the ability of an electric current to flow through a gas under certain circumstances. A person may be seriously injured, or even killed by merely touching an exposed ungrounded conductor at high potential.

WHEN HIGH VOLTAGE IS PRESENT, ALL EXPOSED CONDUCTORS OF A
VACUUM SYSTEM MUST BE MAINTAINED AT EARTH GROUND.

- All vacuum components, such as gauges, valves, etc., or parts thereof, that are electrically insulated from the main vacuum system must be reliably connected to an earth ground, or shielded to positively prevent human contact.
- All components utilizing vacuum connections, such as quick connects, taped threads, plastic, glass, rubber tubing, etc., must be reliably grounded.

For example, a metal gauge envelope that is not reliably grounded through its vacuum connector may be grounded by using a metal hose clamp on the gauge, connected by a 12 awg copper wire to the grounded vacuum chamber.

- High voltage can couple through a gas to the internal electrodes of a gauge. Do not touch the exposed pins on any gauge installed on a vacuum system where high voltage is present.

This hazard is not peculiar to this product. It is a characteristic of all vacuum systems having equipment installed that is capable of producing high voltage within the vacuum environment. Check all of your vacuum systems periodically for proper grounding of all exposed conductors.

SPECIFICATIONS

Measuring Range:	1 mTorr to 999 Torr for N ₂ . Operation down to .1 mTorr possible using analog output but requires periodic checking of zero by reducing system pressure to below 1×10^{-5} Torr.
Display resolution:	3 digits from 100 mTorr to 999 Torr. 2 digits from 10 mTorr to 99 mTorr. 1 digit from 1 mTorr to 9 mTorr.
Ambient operating temperature range:	+4 to +50 °C.
Gauge tube temperature compensation range:	+15 to +50 °C.
Bakeout temperature range (non-operating):	85 °C max. with electronics attached. 150 °C max. with electronics removed.
Output voltage:	0.375 Vdc to 5.659 Vdc nonlinear corresponding to 0 to 1,000 Torr for N ₂ (120 Ω output impedance).
Process control outputs:	Single pole - double throw relay, silver alloy - gold clad contacts. U.L. Rating: 1 A @ 30 Vdc.
Process control adjustment range:	1 mTorr - 990 Torr. 999 Torr = setpoint disabled.

Electrical power:

12 Vdc to 28 Vdc, 3.5 W maximum. Protected against reversals, transients or over-voltages.

Gauge tube:

Internal Volume:
Sensor:

40 cm³ (2.5 in³).
Gold plated tungsten.

Physical size:

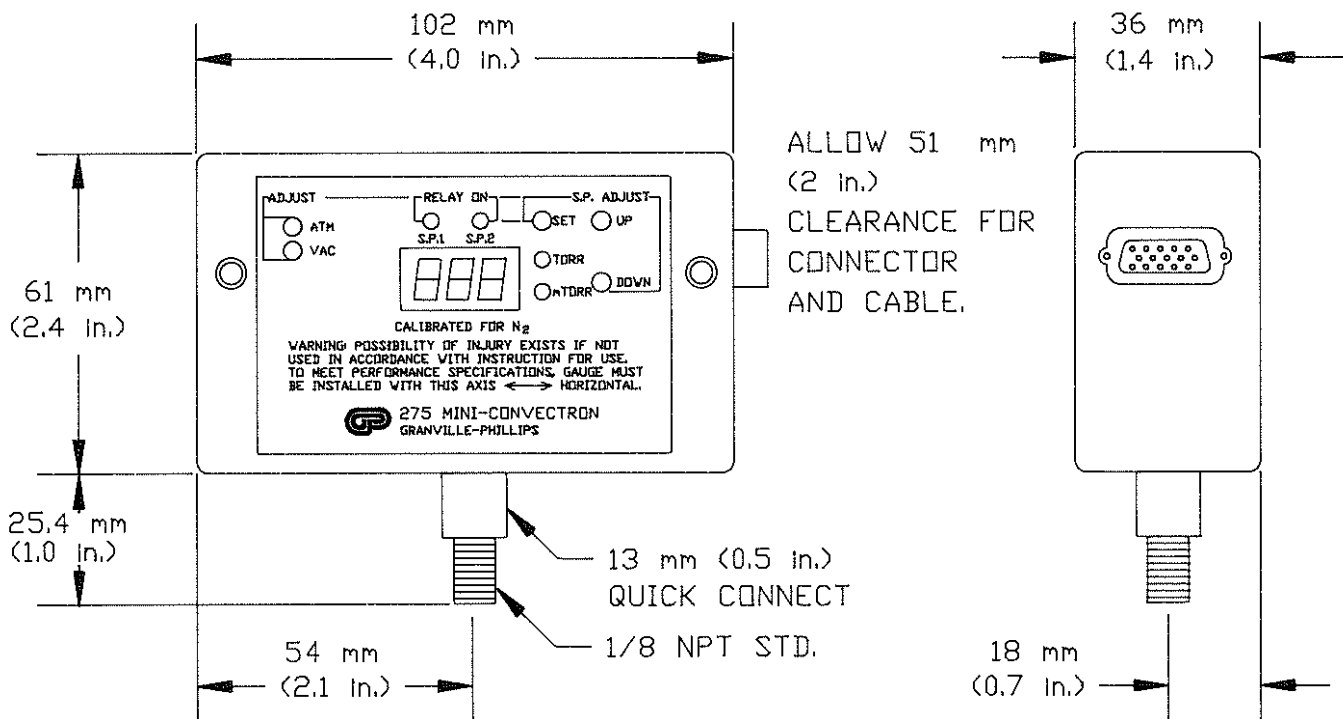

Weight:

.22 kg (.48 lb.)

NOTES

SECTION 1

SAFETY INSTRUCTIONS

SAFETY PAYS, THINK BEFORE YOU ACT. UNDERSTAND WHAT YOU ARE GOING TO DO BEFORE YOU DO IT. READ THIS INSTRUCTION MANUAL BEFORE INSTALLING, USING, OR SERVICING THIS EQUIPMENT. IF YOU HAVE ANY DOUBTS ABOUT HOW TO USE THIS EQUIPMENT SAFELY, CONTACT THE GRANVILLE-PHILLIPS PRODUCT MANAGER FOR THIS EQUIPMENT AT THE ADDRESS LISTED ON THIS MANUAL.

Explosive Gases

Do not use the gauge tube to measure the pressure of combustible gas mixtures. The sensing element normally operates at only 125 °C, but it is possible that momentary transients or controller malfunction can raise the sensor above the ignition temperature of combustible mixtures which might then explode causing damage to equipment and injuring personnel.

Limitation on use of Compression Mounts

Do not use a compression mount (quick connect) for attaching the gauge tube to the system in applications resulting in positive pressures in the gauge tube. Positive pressures might blow the tube out of a compression fitting and damage equipment and injure personnel. The Series 275 gauge should not be used above 1000 Torr or 1333 mbar true pressure.

Tube Mounting Position

If the gauge tube will be used to measure pressures greater than 1 Torr, the tube must be mounted with its axis horizontal. Although the gauge tube will read correctly below 1 Torr when mounted in any position, erroneous readings will result at pressures above 1 Torr if the tube axis is not horizontal. Erroneous readings can result in over or underpressure conditions which may damage equipment and injure personnel.

Overpressure

Series 275 gauges should not be used above 1000 Torr true pressure. Do not use above 1000 Torr true pressure. **SERIES 275 INSTRUMENTS ARE FURNISHED CALIBRATED FOR N₂.** They also measure the pressure of air correctly within the accuracy of the instrument. Do not attempt to use a Series 275 gauge calibrated for N₂ to measure or control the pressure of other gases such as argon or CO₂, unless accurate conversion data for N₂ to the other gas is properly used. If accurate conversion data is not used or improperly used, a potential overpressure explosion hazard can be created under certain conditions.

A pressure relief valve should be installed in the system should the possibility of exceeding 1000 Torr (1333 mbar) exist.

Electrical

Before connecting your Mini-CONVECTRON to a power source, be sure that the source is compatible with the power requirements listed.

Electrical Power Requirements

DC voltage source 12 Vdc to 28 Vdc, 3.5 W max.

Chemical

Cleaning solvents, such as trichloroethylene, perchloroethylene, toluene and acetone produce fumes that are toxic and/or flammable. Use only in areas well ventilated to the outdoors and away from electronic equipment, open flames, or other potential ignition sources.

Sensor Failure

If the gauge tube sensor wire fails, the output voltage will indicate below 0 mTorr and the process control relays will be inactivated. The digital display will indicate a single dash ("-") and the mTorr and Torr LEDs will be extinguished.

Tube Contamination

The calibration of the gauge will be seriously affected by any gases which will attack the gold plated sensor and could result in overpressurizing the system. Two primary gases in this category are mercury vapor and fluorine.

SECTION 2

INSTALLATION INSTRUCTIONS

Receiving Inspection

Domestic Shipments

Inspect all material received for shipping damage.

Confirm that your shipment includes all material and options ordered. If materials are missing or damaged, the carrier that made the delivery must be notified within 15 days of delivery in accordance with Interstate Commerce regulations in order to file a valid claim with the carrier. Any damaged material including all containers and packing should be held for carrier inspection. Contact our Customer Service Department, 5675 Arapahoe Avenue, Boulder, Colorado 80303, (303) 443-7660 if your shipment is not correct for reasons other than shipping damage.

International Shipments

Inspect all material received for shipping damage. Confirm that your shipment includes all material and options ordered. If items are missing or damaged the carrier making delivery to the customs broker must be notified within 15 days of delivery.

Example:

If an airfreight forwarder handles the shipment and their agent delivers the shipment to customs the claim must be filed with the airfreight forwarder.

If an airfreight forwarder delivers the shipment to a specific airline and the airline delivers the shipment to customs the claim must be filed with the airline, not the freight forwarder.

Any damaged material, including all containers and packaging, should be held for carrier inspection. Contact our Customer Service Department, 5675 Arapahoe Avenue, Boulder, Colorado 80303, U.S.A. Telephone (303) 443-7660 if your shipment is not correct for reasons other than shipping damage.

Important Precautions for Mini-CONVECTRON Installation

The following precautions in the use and installation of the Mini-Convectron must be observed.

1. It is recommended that the Mini-CONVECTRON be installed with the port oriented vertically downward to ensure that no system condensates or other liquids collect in the gauge tube. The gauge tube axis must be horizontal if it is to be used at pressures above 1 Torr. Although the gauge tube will read correctly below 1 Torr when mounted in any position, erroneous

readings will result at pressures above 1 Torr if the tube axis is not horizontal.

2. Do not use a compression mount (quick connect) for attaching the Mini-CONVECTRON to the system in applications resulting in positive pressures in the gauge tube. Positive pressures might blow the tube out of a compression fitting and damage equipment and injure personnel. Pipe thread or flange mounting systems should be used for positive pressure applications. In any case, the absolute pressure in the tube should not exceed 1000 Torr.
3. Do not perform electrical continuity tests on the Mini-CONVECTRON tube with instruments applying voltages in excess of 1 volt when the tube is at vacuum, or 5 volts when at atmospheric pressure. Exceeding these voltages will damage the sensing element.
4. Keep the tube clean. Do not remove the mounting port cover until you are ready to install the tube.
5. Do not mount the Mini-CONVECTRON in a manner such that deposition of process vapors, upon the internal surfaces of the gauge tube, may occur through line-of-sight access to the interior of the gauge tube.
6. Do not install the Mini-CONVECTRON where high amplitudes of vibration are present. Excessive vibration will cause forced convection at high pressure giving erroneous readings.
7. Do not bake the Mini-CONVECTRON with electronics attached at temperatures exceeding 85 °C.
8. Do not bake the gauge tube with the electronics removed at temperatures exceeding 150 °C.
9. Do not install the gauge tubes where they will be subject to corrosive gases such as mercury vapor or fluorine which will attack the gold plated sensor.
10. For greatest accuracy and repeatability the Mini-CONVECTRON tube should be located in a stable room temperature environment.
11. The port of the Mini-CONVECTRON is not grounded. Installation should be only to grounded systems if lethal voltages are present in the system.



When high voltage is present, all exposed conductors of a vacuum must be maintained at earth ground.

Under certain conditions, dangerous high voltage can be coupled directly to an ungrounded conductor through a gas almost as effectively as through a copper wire connection. This hazard, which is not peculiar to this product, is a consequence of the ability of an electric current to flow through a gas under certain circumstances. A person may be seriously injured, or even killed by merely touching an exposed ungrounded conductor at high potential.

When high voltages are used within the vacuum system and the *CONVECTRON* Gauge envelope is not reliably grounded through its vacuum connection, either a separate ground wire must be added, or the envelope must be shielded to positively prevent human contact. The gauge envelope may be grounded by using a metal hose clamp on the gauge connected by a #12 awg copper wire to the grounded vacuum chamber.

High voltage can couple through a gas to the internal electrodes of a gauge. Do not touch the exposed pins on any gauge installed on a vacuum system where high voltage is present.

Gauge Tube Construction

The transducer is a convection enhanced Pirani gauge providing rapid response, six-decades of pressure transduction, stable calibration, and good accuracy. The Pirani sensing element, R1 of the schematic of Fig. 2-1, is one leg of a Wheatstone Bridge. A temperature compensating network, R2, forms the second leg of the bridge. The temperature sensitive component of this network is mounted inside the gauge tube envelope with the sensor. All other resistors of the bridge are mounted upon the exterior electrical feedthrough pins of the gauge tube. Pin 4 serves as an electrical terminal for construction of the compensating network, R2, but no connection is made therefrom to the controller.

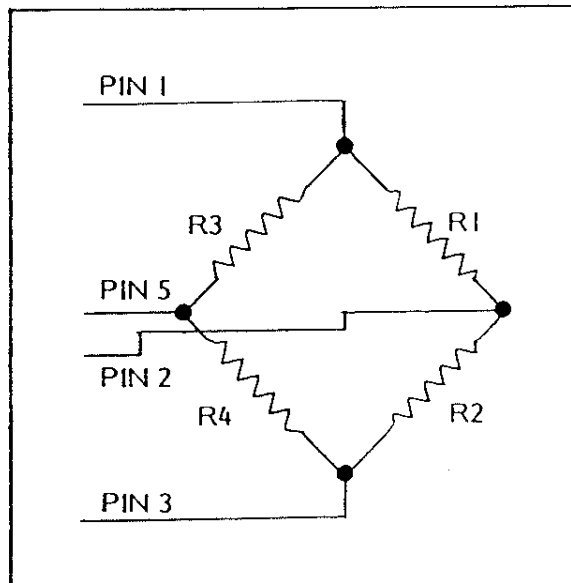

FIG. 2-1 GAUGE TUBE SCHEMATIC

All materials have been chosen for ultra high vacuum service, corrosion resistance and bakeability to 150 °C. The gauge tube envelope is type 304 stainless steel. All metallic joints in the envelope are TIG welded. No solder is used within the envelope. The following materials are exposed to the vacuum: Type 304 stainless steel, Carpenter Alloy 52, Kovar,¹ Kapton® , gold plated tungsten and borosilicate glass.

Mini-CONVECTRON Gauge Tube Orientation

It is important to consider the orientation of the Mini-CONVECTRON if accurate readings above 1 Torr is necessary to prevent overpressure or for other reasons.

Below 1 Torr: The Mini-CONVECTRON will operate and accurately read pressures below 1 Torr when mounted in any orientation. Above 1 Torr: The Mini-CONVECTRON will accurately read pressures above 1 Torr only when mounted with its axis horizontal, preferably with the port pointing vertically downward. It is valuable to point the port downward to facilitate the removal of condensation and other contaminants.

Installation

The Mini-CONVECTRON is designed to be installed by use of the side port fitting only. Adequate strain relief should be incorporated for the I/O connector.

1. Compression Mount (Quick Connect)

Do not use for positive pressure applications.

The gauge tube port is designed to fit a standard 1/2 in. compression (quick disconnect) mount such as the Cajon Co. Ultra-Torr® fittings.

Remove the caplug from the gauge tube port, insert the gauge tube port into the compression fitting and finger tighten the press ring. If a seal is not achieved it is likely due to extreme cleanliness of the O-ring. A light film of vacuum grease, such as Apiezon,² will ensure sealing and is normally preferable to the use of pliers or pipe wrench to further tighten the press ring, You may point the electrical pins of the Mini-CONVECTRON anywhere you wish in a 360 degree horizontal circle for optimum routing of the cable.

2. 1/8 NPT Mount

The threads on the Mini-CONVECTRON port will fit a standard 1/8 NPT female fitting. Wrap the threads of the gauge tube

¹Trademark of Carpenter Technology

²Trademark of James G. Biddle Co.

port with Teflon tape and screw these threads into the system fitting hand tight. Do not use any wrench or tool. The Mini-CONVECTRON body functions adequately as its own wrench. Tighten only sufficiently to achieve a seal. When the threads have been tightened to the point where a seal is just achieved, about one-half turn additional tightening is all that can be gained without overstressing the tube port.

3. Other Mounts

In addition to the standard gauge tube which provides a 1/2 in. compression mount and 1/8 NPT male thread, a variety of other mounting options are available. They include 1-5/16 in. and 2-3/4 in. Conflat type flanges, Cajon[®] VCO[®] and VCR[®] type fittings and NW10KF, NW16KF, NW25KF, NW40KF, and NW50KF flanges.

4. Grounding



Be aware that an electrical discharge through a gas may couple dangerous high voltage directly to an ungrounded conductor almost as effectively as would a copper wire connection. A person may be seriously injured or even killed by merely touching an exposed ungrounded conductor at high potential.

This hazard is not peculiar to this product.

Provide a connection to ground for other instruments with electrodes in the vacuum system possibly exposed to high voltage electrical discharges.

Provide a connection to ground for each ungrounded metal component in, on or around the vacuum system, including the gauge envelopes, which personnel may touch and which can potentially be exposed to high voltage electrical discharges within the vacuum system. For example, a metal bell jar resting on an organic O-ring must be connected to ground if high voltage sources are present in the vacuum system.



Grounding this product does not and cannot guarantee that other components of the vacuum system are all maintained at earth ground.



All conductors in, on, or around the vacuum system exposed to potential high voltage electrical discharges must either be shielded at all times to protect personnel or must be connected to earth ground at all times.

I/O Connector Wiring

The 15 pin "D" type connector has the following pin assignments:

<u>Pin No.</u>	<u>Function</u>
1	No connection
2	No connection
3	Power input 12 Vdc to 28 Vdc @ 3.5 W max.
4	Power ground and connector shell
5	Analog output voltage
6	Signal ground
7	No connection
8	No connection
9	No connection
10	Process relay #1 normally open contact
11	Process relay #2 normally open contact
12	Process relay #2 common
13	Process relay #2 normally closed contact
14	Process relay #1 normally closed contact
15	Process relay #1 common

Refer to the Specifications Section for maximum rating of the process relay contacts.

SECTION 3

OPERATING INSTRUCTIONS

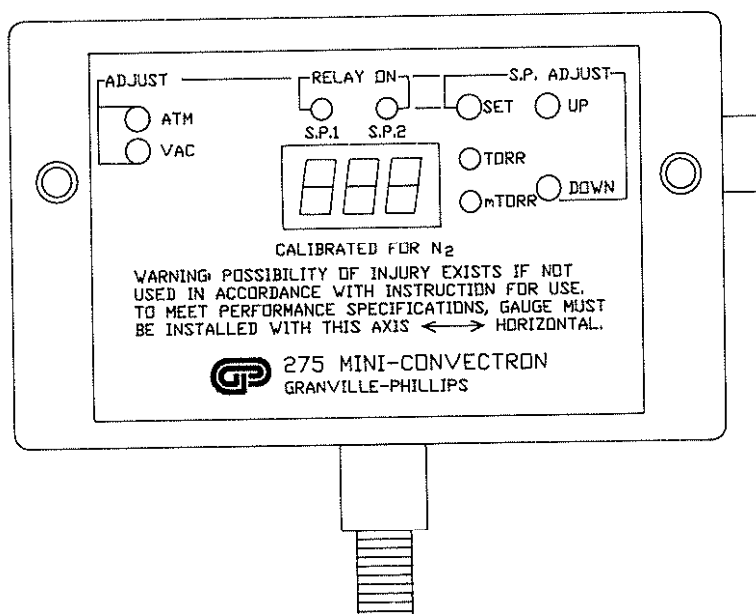

Fig. 3-1 Front Panel Indicators and Adjustments

Purpose of Front Panel Features

- Vacuum Adjustment - Adjustment is provided to restore accuracy of the analog output voltage and display at low pressures.
- Atmosphere Adjustment - Adjustment is provided to set the analog output voltage and display to correspond to known atmospheric pressure.
- Set Point Adjustments - Momentary push-button switches are accessible through the front panel SET, UP and DOWN holes for programming the setpoint relays to activate on falling pressure at the desired pressure.

Setting Process Control Relay Setpoints

1. Activate the program setpoint function by depressing the SET switch accessible through the front panel.
 - a. Depress the switch once for access to S.P.1 relay and twice for S.P.2 relay programming function. The RELAY ON LED will flash on and off when ready to program each respective setpoint.

display will revert back to pressure measurement.

2. Depress the UP or DOWN S.P. ADJUST switch to program the desired activation pressure. The relay will activate on falling pressure only when the indicated pressure is equal to the programmed setpoint. Pin-out information for the process relay contacts is given in Section 3. In order to prevent oscillation around the trip point, there is a hysteresis band of approximately 10% of reading plus one significant digit. Setting the process control setpoints to 999 Torr will disable setpoint operation.

Analog Output

Fig 5-3 is a chart of the analog output voltage for various gases. The impedance of this output is 390 ohms. This output is normalized for 0.375 Vdc at vacuum and 5.534 Vdc at 760 Torr for N₂ or air. Should this output drop to approximately 0.10 Vdc, an open sensor in the gauge tube is a distinct possibility. Should it drop to 0 Vdc, the input power of 12 Vdc to 28 Vdc should be investigated.

Long Cable Operation

There is no restriction on cable length since the control circuitry is located right at the sensor. This is true as long as the input voltage remains within the range of 12 Vdc to 28 Vdc.

Bakeout

The Mini-CONVECTRON is designed to allow bakeout temperature of up to 85 °C with the electronic circuitry attached but not operational. Should a higher bakeout temperature be desired, up to a maximum of 150 °C, proceed as follows:

Note: Since the Mini-CONVECTRON contains static sensitive components, the guidelines of Chapter 6 must be followed.

1. Remove the "D" type I/O connector. Remove the two screws holding the enclosure top to the enclosure.
2. Gently rock the enclosure away from the printed circuit board/gauge tube assembly and remove.
3. Disengage the gauge tube from the printed circuit board spring loaded sockets.
4. Perform the bakeout of the system with up to a maximum of 150 °C measured temperature at the gauge tube envelope surface.
5. After cooldown, plug the gauge tube back into the printed circuit board and install the enclosure over the assembly. Note the card guides molded into the enclosure.

6. Replace the cover and the I/O connector.

Power

The Mini-CONVECTRON is in operation anytime that the 12 Vdc to 28 Vdc input voltage is applied. The sensor of the gauge tube runs at a temperature of approximately 120 °C. Gauge tube life is not affected by hours of operation.

NOTES

10/1/2024 10:10:10 AM

SECTION 4

CALIBRATION

Each Mini-CONVECTRON gauge tube is individually CALIBRATED FOR N₂ and temperature compensated prior to leaving the factory. Each controller is individually calibrated to provide accurate readout of N₂ or air pressure; therefore, initial calibration should not be necessary. See Section 5 for use with gases other than N₂ and air. If the tube becomes contaminated or does not read correctly, the Mini-CONVECTRON can be calibrated with the front panel adjustments by performing the following steps.

Analog Output Voltage Monitor

Vacuum Adjust

1. Evacuate the system to a pressure less than 10⁻⁴ Torr.
2. While monitoring the analog output voltage adjust the vacuum potentiometer for a reading of 0.375 Vdc.

Atmosphere Adjust

1. Allow the system pressure to rise to atmospheric pressure of air.
2. While monitoring the analog output, adjust the atmosphere potentiometer for a voltage corresponding to the absolute pressure corresponding to your location. Refer to Fig. 4.1 for typical altitude/Torr/voltage relationships.

<u>Altitude in Feet Above Sea Level</u>	<u>Pressure In Torr (N₂, Air)</u>	<u>Analog Output Voltage Vdc</u>
0	760	5.534
1000	733	5.513
2000	707	5.493
3000	681	5.473
4000	656	5.454
5000	632	5.435
6000	609	5.417
7000	586	5.399
8000	564	5.382
9000	543	5.366
10,000	523	5.350

Fig. 4-1

Digital Display Adjust

Vacuum Adjust

1. Evacuate the system to a pressure less than 10^{-4} Torr.
2. Adjust the VAC potentiometer for a display of 0 mTorr. If adjusted too far counterclockwise, the display will indicate -0 mTorr. Correct adjustment is when '-' sign just extinguishes.

Atmosphere Adjust

1. Allow the system pressure to rise to atmospheric pressure of air or, preferably, backfill with N_2 to a known pressure at or near atmospheric pressure.
2. Adjust the ATM potentiometer for a display corresponding to the absolute pressure corresponding to your location or that indicated by the pressure measurement standard on your system. Refer to Fig. 4.1 for typical altitude/torr/voltage relationships.

SECTION 5

USE WITH GASES OTHER THAN N₂ AND AIR

It is important to understand that the analog output voltage from a Series 275 Mini-CONVECTRON depends on the type of gas in the tube, on the orientation of the tube axis, and on the gas pressure in the tube. Series 275 Mini-CONVECTRONS are supplied calibrated for N₂ when the axis of the gauge tube is horizontal. The indicated reading for air is the same as for N₂ within the accuracy of the instrument. With certain safety precautions, the Series 275 Mini-CONVECTRON may be used to measure pressure of other gases.

Series 275 Mini-CONVECTRON gauges are thermal conductivity gauges of the Pirani type. These gauges transduce gas pressure by measuring the heat loss from a heated sensor wire maintained at constant temperature. For gases other than N₂ and air the heat loss is different at any given true pressure and thus the analog output voltage will be different.

Figs. 5-1 and 5-2 show the relationship of true pressure for N₂ (air) - vs - analog output voltage. This graph was plotted using the data taken from Fig. 5-3 which is the analog output voltage versus true pressure for various gases. This data can be used in your application by performing a curve fit for the gas involved with your process. It can also be plotted out on the graphs of Figs. 5-1 and 5-2 if you desire to see how it compares with N₂ or air.

For gases not listed, or for a mixture of gases, it will be necessary to generate your own calibration curve using an acceptable gas independent transfer standard such as a capacitance manometer. The maximum usable analog voltage output will depend upon the input voltage used. Subtract 4 Vdc from VIN to determine the maximum analog voltage output. This will determine the highest readable pressure for the gas involved.

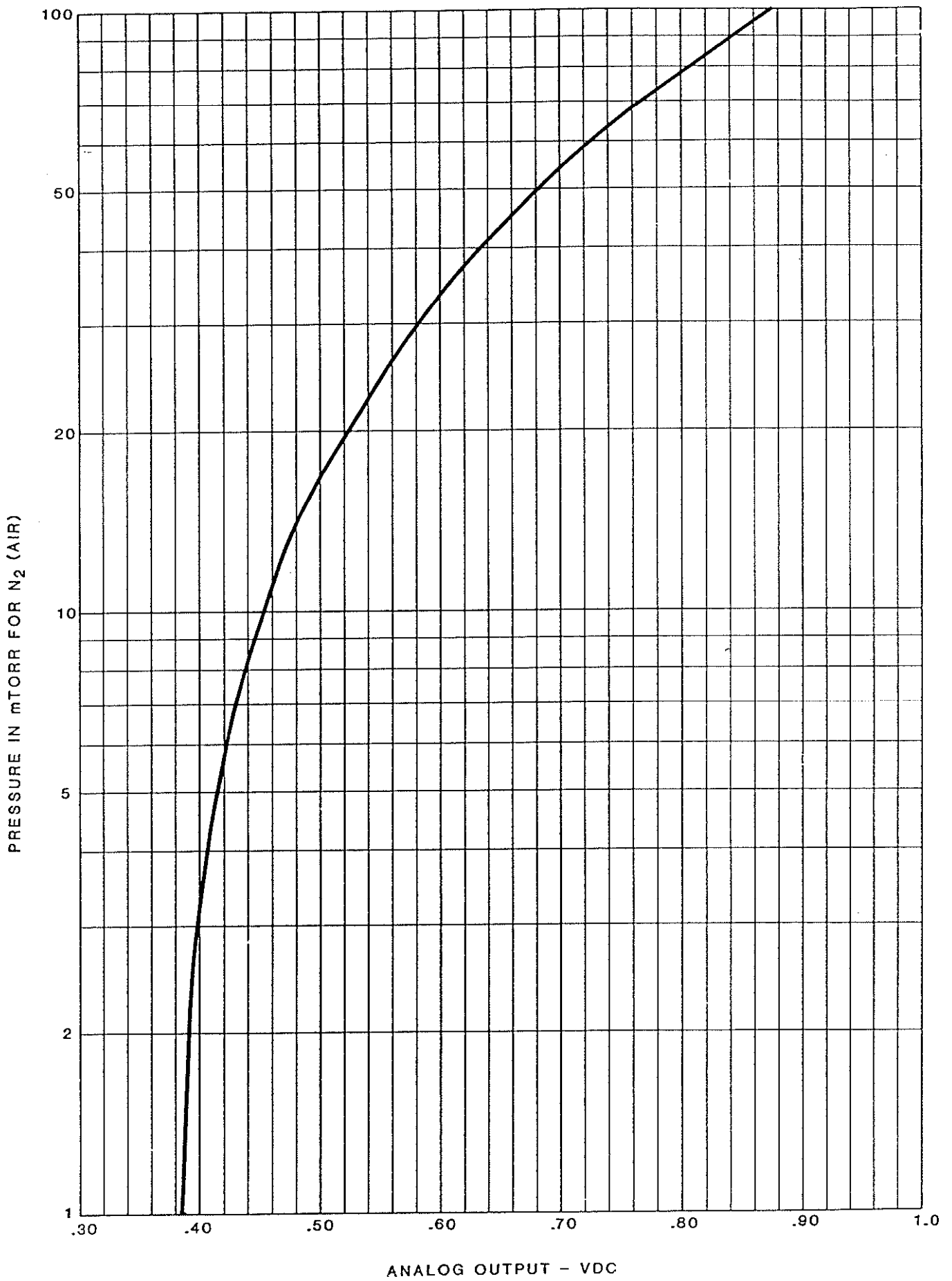

Fig 5-1 Output Voltage vs Indicated Pressure

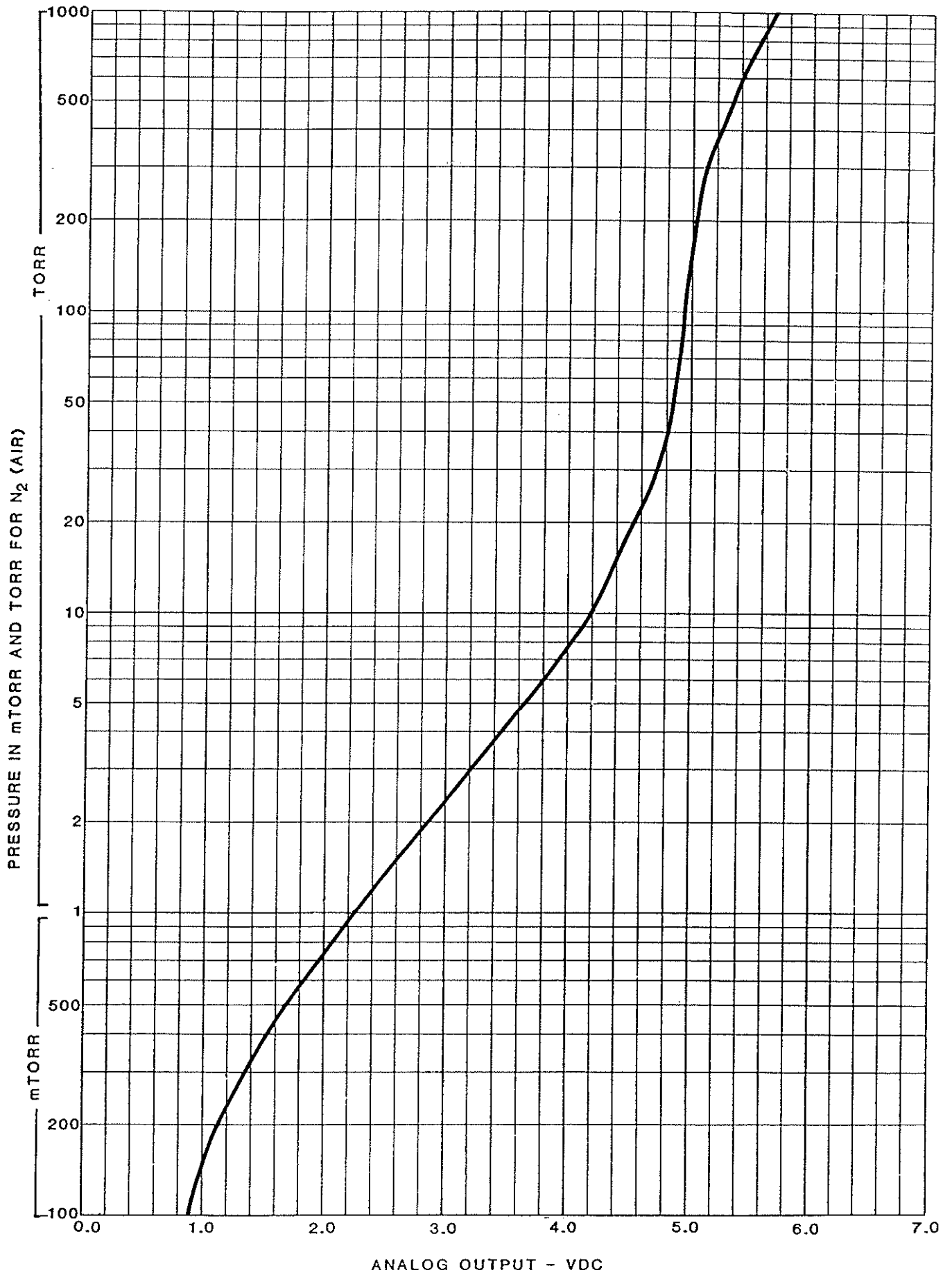

Fig. 5-2 Output Voltage vs Indicated Pressure

True Pressure Torr/mTorr	N ₂ (Air)	Argon	Helium	O ₂	CO ₂	KR	Freon12	Freon22	D2	Ne	CH ₄
0	.375	.375	.375	.375	.375	.375	.375	.375	.375	.375	.375
.1 mTorr	.376	.3757	.3755	.376	.376	.3755	.376	.376	.376	.3757	.3766
.2 mTorr	.377	.376	.3765	.377	.377	.3768	.378	.378	.377	.3763	.3780
.5 mTorr	.379	.378	.379	.380	.381	.3772	.382	.381	.381	.3782	.3825
1 mTorr	.384	.381	.382	.384	.385	.379	.388	.388	.386	.381	.3896
2 mTorr	.392	.387	.389	.392	.395	.384	.401	.400	.396	.388	.403
5 mTorr	.417	.403	.409	.417	.412	.395	.437	.432	.425	.405	.438
10 mTorr	.455	.429	.441	.453	.462	.415	.488	.480	.470	.433	.492
20 mTorr	.523	.477	.497	.521	.536	.451	.581	.566	.549	.484	.584
50 mTorr	.682	.595	.637	.679	.705	.544	.778	.764	.727	.608	.796
100 mTorr	.878	.745	.814	.868	.900	.668	1.009	.990	.944	.768	1.053
200 mTorr	1.155	.962	1.068	1.141	1.179	.847	1.315	1.291	1.265	1.002	1.392
500 mTorr	1.683	1.386	1.589	1.664	1.668	1.194	1.826	1.805	1.914	1.469	2.014
1 Torr	2.217	1.818	2.164	2.195	2.172	1.536	2.257	2.247	2.603	1.976	2.632
2 Torr	2.842	2.333	2.939	2.814	2.695	1.921	2.647	2.666	3.508	2.631	3.313
5 Torr	3.675	3.028	4.387	3.672	3.316	2.429	3.029	3.090	5.059	3.715	-
10 Torr	4.206	3.480	5.774	4.225	3.670	2.734	3.204	3.330	6.361	4.605	4.699
20 Torr	4.577	3.801	7.314	4.620	3.903	2.966	3.308	3.414	-	5.406	5.172
50 Torr	4.846	4.037	4.037	4.916	4.071	3.075	3.430	3.509	-	6.159	5.583
100 Torr	4.945	4.122	4.122	5.026	4.154	3.134	3.618	3.660	-	6.483	5.720
200 Torr	5.019	4.192	4.192	5.106	4.336	3.269	3.827	3.883	-	6.661	5.860
300 Torr	5.111	4.283	4.283	5.200	4.502	3.384	3.938	4.005	-	6.726	-
400 Torr	5.224	4.386	4.386	5.315	4.621	3.466	4.016	4.088	-	6.767	6.103
500 Torr	5.329	4.477	4.477	5.422	4.708	3.526	4.076	4.151	-	6.803	-
600 Torr	5.419	4.550	4.550	5.515	4.775	3.573	4.124	4.203	-	6.843	6.342
700 Torr	5.495	4.611	4.611	5.592	4.830	3.613	4.166	4.247	-	6.890	-
760 Torr	5.534	4.643	4.643	5.633	4.860	3.632	4.190	4.271	-	6.920	-
800 Torr	5.558	4.663	4.663	5.658	4.877	3.645	4.203	4.286	-	6.942	6.519
900 Torr	5.614	4.706	4.706	5.713	4.919	3.674	4.237	4.321	-	7.000	-
1000 Torr	5.659	4.745	4.745	5.762	4.955	-	4.270	4.354	-	7.056	6.642

Fig. 5-3 Bridge Analog Output Voltages (Vdc) for Various Gases

SECTION 6
MAINTENANCE

General Information

Although the Mini-CONVECTRON was designed using as many commonly available components as possible, thus allowing easy service, it is still recommended that only qualified technical personnel attempt repairs.

Should difficulties be encountered in the use of your Mini-CONVECTRON, the following list of symptoms and remedies, along with the schematics, can prove useful in quickly getting back into operation. Since the majority of parts are readily available at local electronics supply stores, it may, in some cases, prove most expedient for you to repair minor troubles should they occur.

If the prescribed remedies do not correct the troubles, or if additional assistance or special parts are required, contact the Technical Service Department, Granville-Phillips, 5675 Arapahoe Avenue, Boulder, Colorado, 80303. Telephone: (303)-443-7660. Repairs properly made with equivalent electronic parts and rosin core solder, which do not damage other portions of the unit, do not represent a violation of the warranty.

Check the following list for the observed symptoms. This listing of symptoms and remedies is not complete, but should be sufficient to solve most problems. All possible causes of failure should be thoroughly explored before attempting any component replacement.

Guidelines

Since the Mini-CONVECTRON contains static-sensitive electronic parts, the following precautions must be followed when troubleshooting:

- 1) Use a grounded, conductive work surface.
- 2) Use static dissipative envelopes to store or ship printed circuit boards.
- 3) **Do not** handle the printed circuit board more than absolutely necessary, and only when wearing a ground strap.
- 4) **Do not** use an ohmmeter for troubleshooting. Rely on voltage measurements.
- 5) Use grounded-type soldering irons only.

Mini-CONVECTRON Disassembly

For most troubleshooting procedures it will be required that the printed circuit board and gauge tube be removed from the enclosure. To accomplish this proceed as follows:

1. Remove the two screws holding on the enclosure cover. Remove the cover.
2. Pull up on the edge of the PC board and remove the board with gauge tube attached from the enclosure.
3. To remove the gauge tube from the PC board simply unplug from the four sockets on the board.
4. For assembly, reverse this procedure.

For troubleshooting, a 15 pin "D" connector with only the 12 Vdc to 28 Vdc input power and ground connected will be most useful.

SYMPTOM

1. Analog output voltage reads zero Vdc.
2. Analog output voltage reads less than +.12 Vdc or greater than +6 Vdc. Digital display indicates a single "-".

POSSIBLE CAUSE

1. No input power. Verify that there is +12 Vdc to +28 Vdc at pin 3 of the I/O connector with respect to pin 4.
1. Gauge tube failure. Test for gauge tube failure. Measure the resistance between the following terminals with the gauge tube at atmospheric pressure and an ohmmeter which can not apply more than 10 mA.

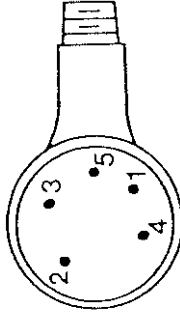

- | | |
|---------|-----------------|
| 1 to 2: | 20 to 30 ohms |
| 2 to 3: | 50 to 60 ohms |
| 1 to 5: | 175 to 190 ohms |

Note: If the resistance from pins 1 to 2 reads about 800 ohms, the sensor wire in the gauge tube is broken.

Troubleshoot and repair.

2. Bridge amplifier failure. All of this circuitry is located on the small PC board that the gauge tube plugs into. Check for input power to this board across the two outside fingers of the small board where it is soldered into the large board. Check that the bridge output voltage between the middle finger and the bottom finger is approximately 6 Vdc with the gauge tube at atmosphere.

REMEDY

- Correct reason for lack of input power.
- Replace gauge tube.

SYMPTOM

POSSIBLE CAUSE

3. Signal conditioner circuit failure. If the bridge output voltage is correct the amplifier stage U2 and associated circuitry should be checked.

REMEDY
Troubleshoot and repair.

3. Analog output voltage cannot be calibrated to the specified value using the vacuum and atmosphere adjust potentiometer.

1. Gauge tube contaminated with material from vacuum system.

Clean gauge tube. If not effective replace the gauge tube.

Cleaning

Note: Prior to cleaning, the gauge tube must be removed from the electronics as described on pages 6-1 and 6-2. Cleaning solvents can damage electronic components or the enclosure.

When the fine sensor wire is so contaminated with oil or other films that its emissivity is appreciably altered, a change of calibration will result. Cleaning with trichloroethylene, perchloroethylene, toluene, or acetone is possible but it must be done very carefully so as not to damage the sensor. **CAUTION:** The fumes from any of these solvents can be dangerous to your health if inhaled and they should be used in well ventilated areas exhausted to the outdoors. Acetone and toluene are highly flammable and should be used away from open flame or electrical equipment. Hold the tube with the main body horizontal and the port projecting upward at an angle of 45° and slowly fill it with solvent using a standard wash bottle with the spout inserted in the port to where it touches the screen. Let the solvent stand in the tube for at least ten minutes. Do not shake the tube if the tube is only partially filled as liquid forces on the sensor can become large enough to affect the transducer calibration. If the tube is completely filled, shaking is not helpful. To drain the tube, position it horizontally with the port facing downward. By slightly warming the tube, a positive pressure will build up internally forcing the solvent out past the screen. Then allow the tube to dry overnight with the port vertically downward and uncapped. Be certain no solvent odor remains before reinstalling tube on system.

2. The gold plating on sensor has been attacked by a gas such as fluorine or mercury vapor changing its emissivity and/or resistance.

Replace the gauge tube. Cleaning cannot solve this problem.

SYMPTOM

4. Analog output voltage indicating a pressure in system vastly different than being observed by supporting gauges.
5. Process relay LED indicator on but process not functioning.
6. Process relay will not energize.

POSSIBLE CAUSE

1. Gas composition on system not what user believes it to be. This can be caused by selective gas pumping process in use, outgassing of product, etc.
1. Defective relay contacts. Check that load is within specified rating of relay and that it is non-inductive.
1. Circuit problem.
2. Sensor of gauge tube open and analog output is below .10 volts.

REMEDY

- Determine gas composition and calibrate accordingly.
- Replace relay. Correct loading.
- Troubleshoot and repair.
- Replace gauge tube.

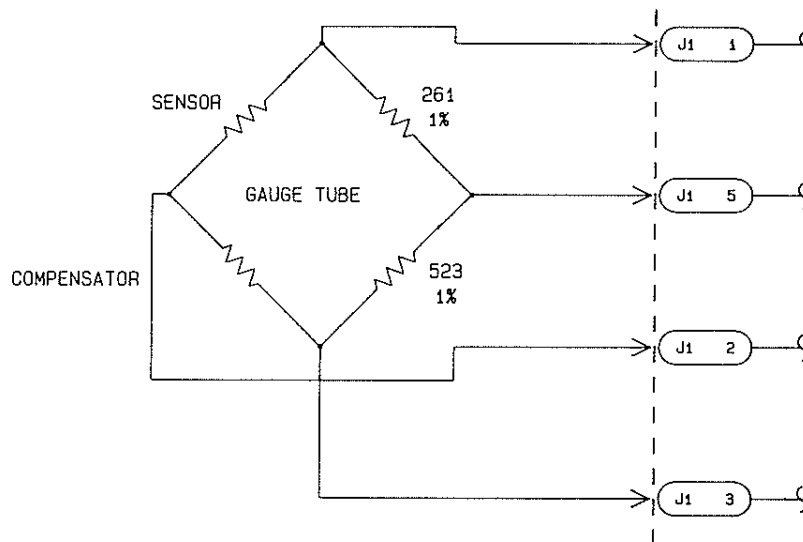

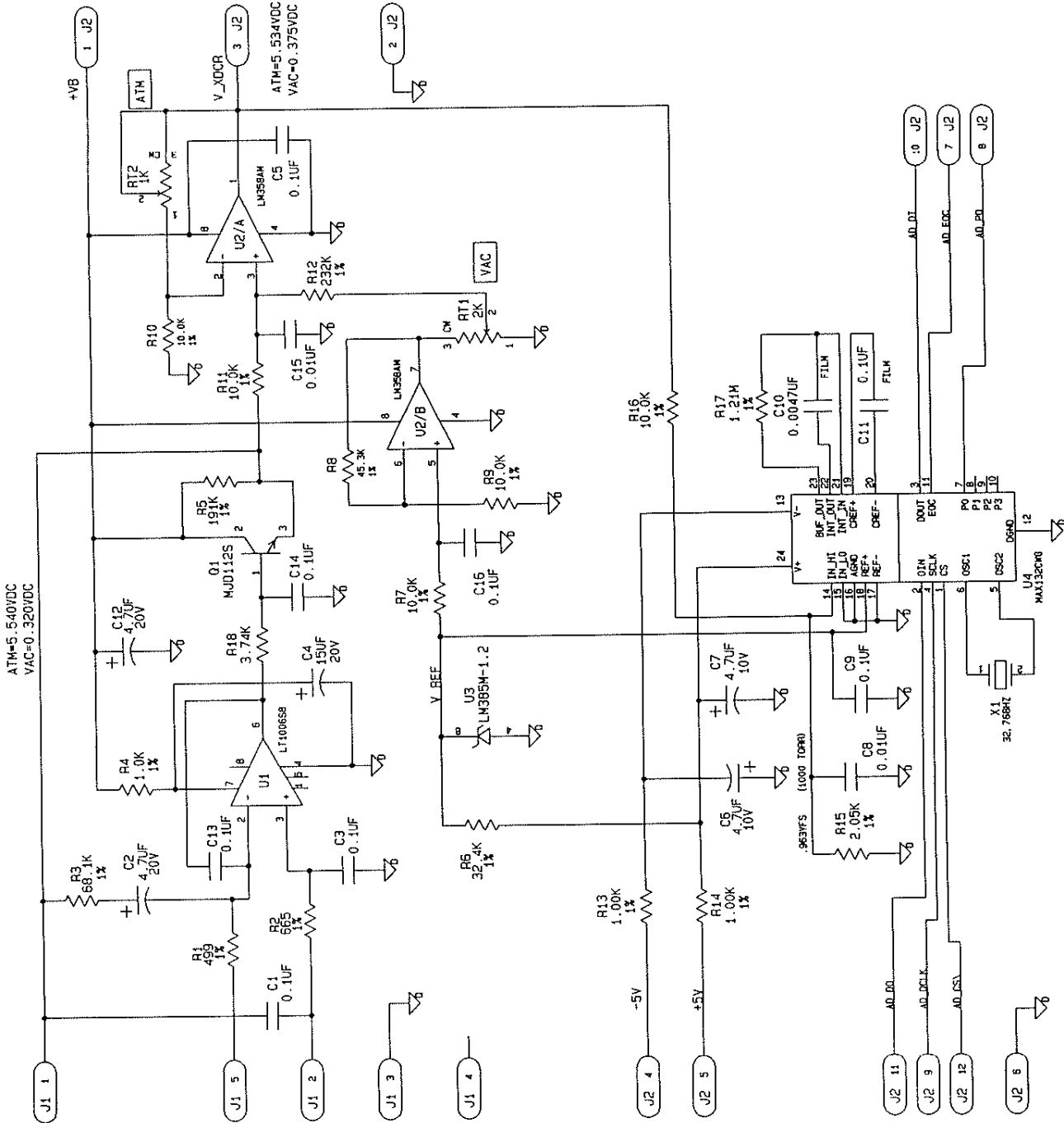

SCHMATIC, 275 DIGITAL DISPLAY BRIDGE

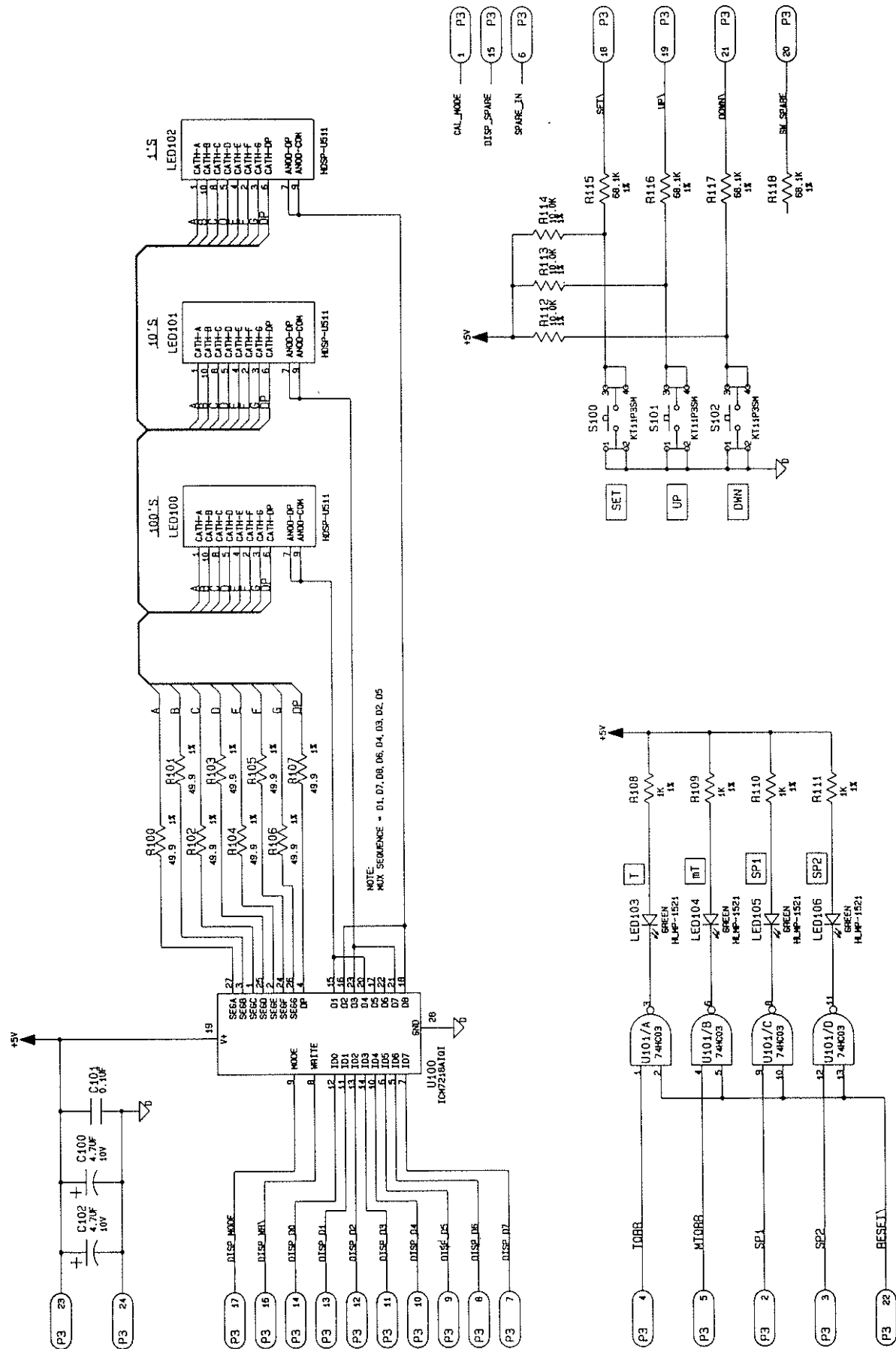

SCHEMATIC, DIG DISPLAY

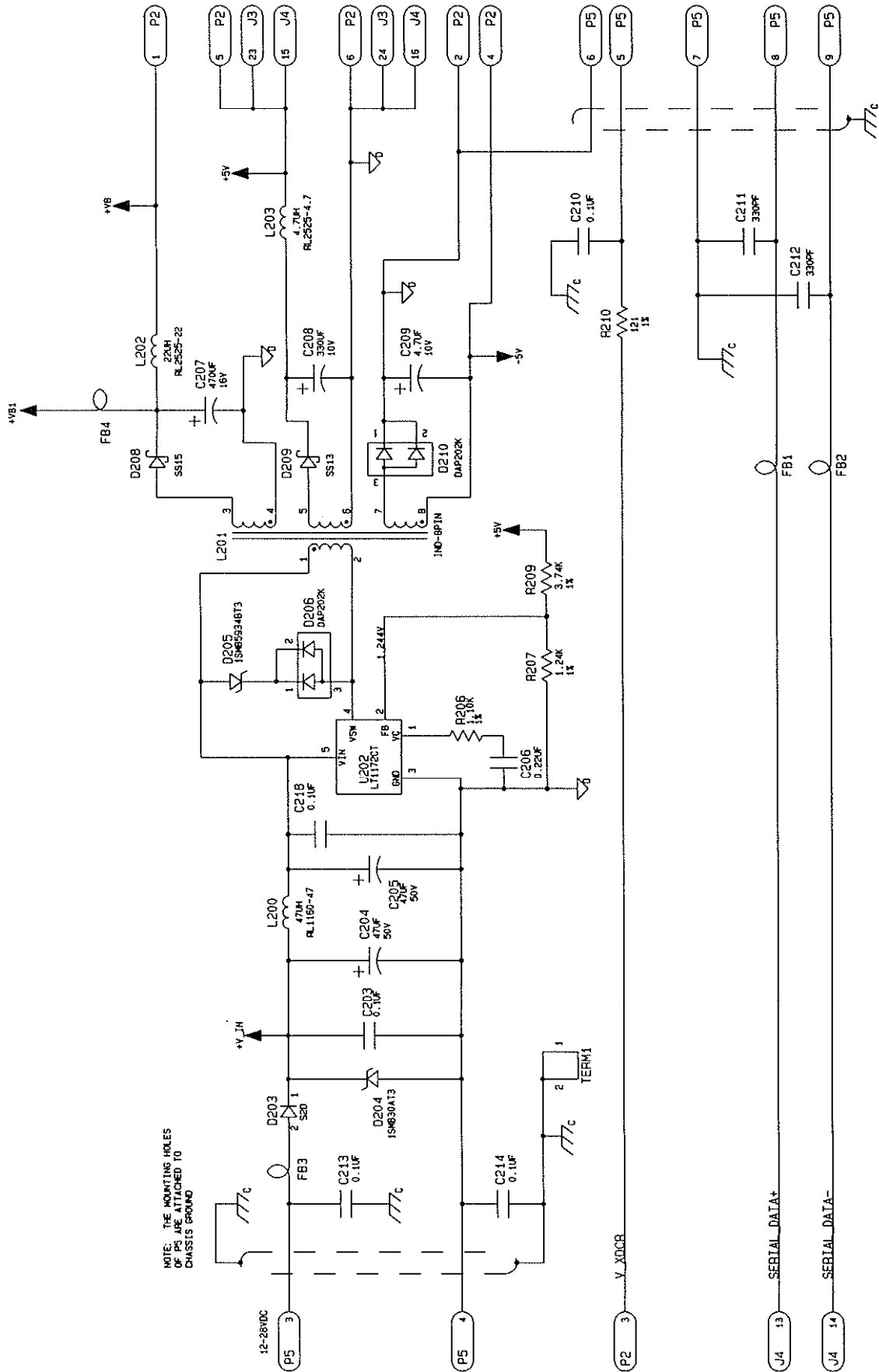

SCHEMATIC, 275 DIGITAL POWER

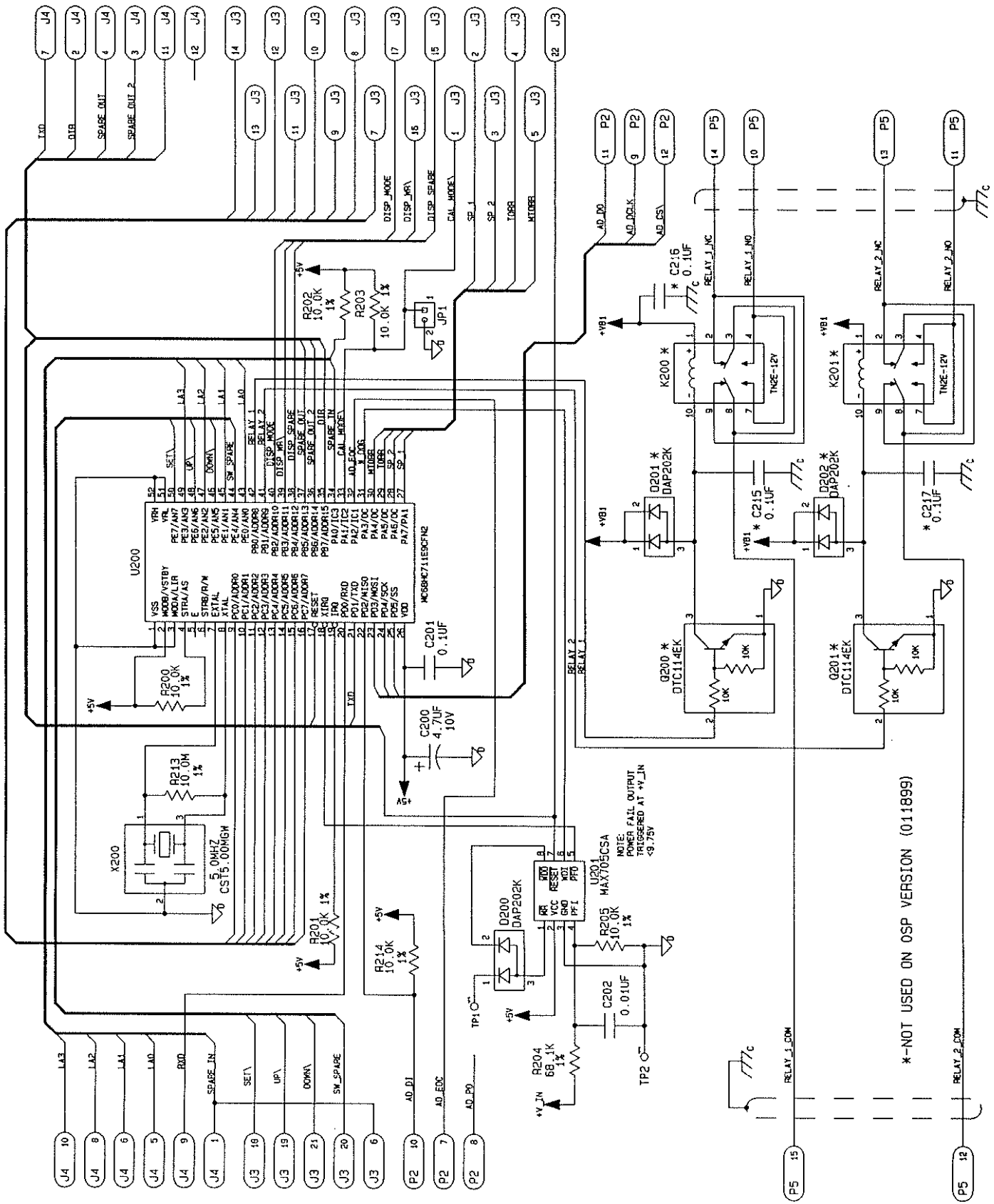

SCHEMATIC, 275 DIGITAL DISPLAY MAIN

*-NOT USED ON OSP VERSION (011899)

NOTE:
POWER FAIL OUTPUT
TRIGGERED AT +V_IN
<9.75V

NOTES

NOTES