

Series 275

Granville-Phillips® Mini-Convectron® Module with RS-485 and Dual Process Relays



Instruction Manual

Instruction manual part number 275545

Revision 05 - May 2008

Series 275

Granville-Phillips® Mini-Convectron® Module with RS-485 and Dual Process Relays

This Instruction Manual is for use with Granville-Phillips Series 275 Mini-Convectron Modules with RS-485 and dual process relays. A list of applicable catalog numbers is provided on the following page.



To order products online, email www.brooks.com

For customer service, 24 hours per day, 7 days per week, every day of the year including holidays, toll-free within USA, phone 1-800-367-4887

For customer service within the USA, 8 AM to 5 PM, weekdays excluding holidays:

- Toll-free, phone: 1-800-776-6543
- Phone: 1-303-652-4400
- FAX: 1-303-652-2844
- Email: co-csr@brooks.com

Instruction Manual

Granville-Phillips® Mini-Convectron® Module with RS-485 and Dual Process Relays

Catalog numbers for Series 275 Mini-Convectron Modules

This manual is for use only with the following catalog numbers:

(20)275318	(20)275507-EU	275507-EU	275527-EU
275528-EU	275529-EU	275530-EU	275531-EU
275532-EU	275533-EU	275534-EU	275535-EU
275536-EU	275546-EU	275546-EU-1	275585-EU
			275546-##-#

275546 - # # - #

Sensor Type:

Gold-Plated Tungsten
Platinum

G
P

Flange/Fitting:

1/8 NPT / 1/2 inch tubulation
1/4 inch VCR-type female fitting
1/2 inch VCR-type female fitting
NW16KF flange
NW25KF flange
NW40KF flange
1.33 inch (NW16CF) ConFlat-type flange
2.75 inch (NW35CF) ConFlat-type flange

P
Q
R
D
E
K
F
G

Measurement Units:

Torr
mbar
pascal

T
M
P

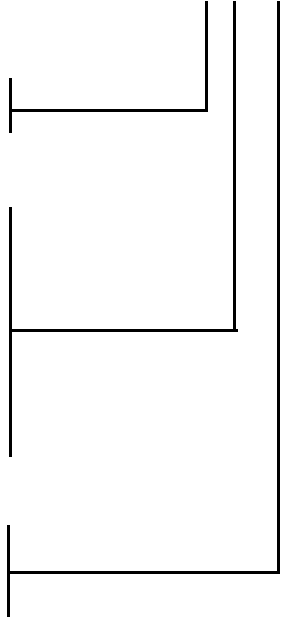

Table of Contents

Chapter 1		4
	Safety Instructions	7
	Safety introduction	7
	Damage requiring service	9
	Overpressure	10
	Warranty information	13
	Service guidelines	13
	FCC verification	14
	Canadian users	14
Chapter 1	Introduction	15
	1.1 Introduction	15
	1.2 Using this manual	16
Chapter 2	Installation	17
	2.1 Receiving inspection	17
	Domestic shipments	17
	International shipments	17
	2.2 Damaged material	17
	2.3 Important precautions for Mini-Convectron installation	18
	2.4 Gauge tube construction	19
	2.6 Mounting orientation and physical dimensions	20
	Mounting Convectron gauges	20
	Environment	20
	Location	21
	2.7 Grounding	21
	2.8 Gauge mounts	21
	Compression mount/Quick connect	21
	1/8 NPT mount	21
	NW or flange mount	21
	ConFlat flange	22
	2.9 Dimensions	22
	2.10 I/O connector wiring	23
	2.11 RS-485 network wiring	24
Chapter 3	Operation	27
	3.1 Power	27
	3.2 Front panel features	27
	3.3 Digital communications	28
	Syntax/address overview	28
	RS-485 address switch settings	28
	Baud rate, stop bit and parity	28
	Command set	29

	ReaD Convector pressure response	30
	Set Offset Address	30
	Set span (typically at atmospheric pressure)	31
	Set zero (at or near vacuum)	32
	Set setpoint 2 trip point	33
	Set setpoint 1 trip point	33
	Read setpoint 2 trip point	33
	Read setpoint 1 trip point	34
	Read Mini-Convector firmware version	34
	Set factory default	34
	Set baud rate	34
	Set parity to 8 bits, none	35
	Set parity to 7 bits, odd	35
	Set parity to 7 bits, even	35
	Set frequency	35
	Reset module	35
	Set pressure units of measure	36
	Read pressure units of measure	36
	Command – response timing	36
	RX, TX timing	37
Chapter 4	Calibration	39
	4.1 Calibration	39
	Vacuum adjust	39
	Atmosphere adjust	40
	4.2 Use with gases other than N ₂ and air	40
Chapter 5	Maintenance	47
	5.1 General information	47
	5.2 Guidelines	47
	5.3 Mini-Convector disassembly	47
	5.4 Symptoms and possible causes	48
	5.5 Returning a Mini-Convector module for service	50

Safety Instructions

Safety introduction

START BY READING THESE IMPORTANT SAFETY INSTRUCTIONS AND NOTES collected here for your convenience and repeated with additional information at appropriate points in these instructions.



These safety alert symbols in this manual or on the Product rear panel, mean caution – personal safety, property damage or danger from electric shock. Read these instructions carefully.

In these instructions the word “product” refers to the Mini-Convector Module and all of its approved parts and accessories.

NOTE: These instructions do not and cannot provide for every contingency that may arise in connection with the installation, operation, or maintenance of this product. Should you require further assistance, please contact Brooks Automation, Inc. at the address on the title page of this manual.

This product has been designed and tested to offer reasonably safe service provided it is installed, operated, and serviced in strict accordance with these safety instructions.



Failure to comply with these instructions may result in serious personal injury, including death, or property damage.

These safety precautions must be observed during all phases of operation, installation, and service of this product. Failure to comply with these precautions or with specific warnings elsewhere in this manual violates safety standards of design, manufacture, and intended use of the instrument. Brooks Automation, Inc. disclaims all liability for the customer's failure to comply with these requirements.



The service and repair information in this manual is for the use of Qualified Service Personnel. To avoid shock, do not perform any procedures in this manual or perform any servicing on this product unless you are qualified to do so.

-
- *Read Instructions* – Read all safety and operating instructions before operating the product.
 - *Retain Instructions* – Retain the Safety and Operating Instructions for future reference.
 - *Heed Warnings* – Adhere to all warnings on the product and in the operating instructions.
 - *Follow Instructions* – Follow all operating and maintenance instructions.
 - *Accessories* – *Do not* use accessories not recommended in this manual as they may be hazardous.



To reduce the risk of fire or electric shock, do not expose this product to rain or moisture.



Objects and Liquid Entry – Never push objects of any kind into this product through openings as they may touch dangerous voltage points or short out parts that could result in a fire or electric shock. Be careful not to spill liquid of any kind onto the products.



Do not substitute parts or modify instrument. Because of the danger of introducing additional hazards, do not install substitute parts or perform any unauthorized modification to the product. Return the product to a service facility designated by Brooks Automation, Inc. for service and repair to ensure that safety features are maintained. Do not use this product if it has unauthorized modifications.

Damage requiring service

Disconnect the product from all power sources and refer servicing to Qualified Service Personnel under the following conditions:

- a. When any cable or plug is damaged.
- b. If any liquid has been spilled onto, or objects have fallen into, the product.
- c. If the product has been exposed to rain or water.
- d. If the product does not operate normally even if you follow the operating instructions. Adjust only those controls that are covered by the operation instructions. Improper adjustment of other controls may result in damage and will often require extensive work by a qualified technician to restore the product to its normal operation.
- e. If the product has been dropped or the enclosure has been damaged.
- f. When the product exhibits a distinct change in performance. This indicates a need for service.



Replacement Parts – When replacement parts are required, be certain to use the replacement parts that are specified by Brooks Automation, Inc. or that have the same characteristics as the original parts. Unauthorized substitutions may result in fire, electric shock or other hazards.



Safety Check – Upon completion of any service or repairs to this product, ask the Qualified Service Person to perform safety checks to determine that the product is in safe operating order.



Finite Lifetime – After ten years of normal use or even non-use, the electrical insulation in this product may become less effective at preventing electrical shock. Under certain environmental conditions which are beyond the manufacturer's control, some insulation material may deteriorate sooner. Therefore, periodically inspect all electrical insulation for cracks, crazing, or other signs of deterioration. Do not use if the electrical insulation has become unsafe.



Be aware that when high voltage is present in any vacuum system, a life threatening electrical shock hazard may exist unless all exposed conductors are maintained at earth ground.

This hazard is not peculiar to this product.



Be aware that an electrical discharge through a gas may couple dangerous high voltage directly to an ungrounded conductor almost as effectively as would a copper wire connection. A person may be seriously injured or even killed by merely touching an exposed ungrounded conductor at high potential.

This hazard is not unique to this product.



Install suitable devices that will limit the pressure to the level that the vacuum system can safely withstand. In addition, install suitable pressure relief valves or rupture disks that will release pressure at a level considerably below the pressure that the system can safely withstand.

Overpressure



Series 275 Gauges should not be used above 1000 Torr true pressure.

Series 275 instruments are furnished calibrated for N₂. They also measure the pressure of air correctly within the accuracy of the instrument. Do not attempt to use a Series 275 Gauge calibrated for N₂ to measure or control the pressure of other gases such as argon or CO₂, unless accurate conversion data for N₂ to the other gas is properly used.



If accurate conversion data is not used, or is improperly used, a potential overpressure explosion hazard can be created under certain conditions.

A pressure relief valve should be installed in the system if the possibility of exceeding 1000 Torr (1333 mbar) exists.

Suppliers of pressure relief valves and pressure relief disks are listed in the *Thomas Register* under "Valves, Relief" and "Discs, Rupture."

Confirm that these safety devices are properly installed before installing the product. In addition, check that:

- The proper gas cylinders are installed,
- Gas cylinder valve positions are correct on manual systems, and
- The automation is correct on automated gas delivery systems.

Proper Grounding:

All components of a vacuum system used with this or any similar high voltage product must be maintained at earth ground for safe operation. The power cord of this product shall be connected only to a properly grounded outlet. Be aware, however, that grounding this product does not guarantee that other components of the vacuum system are maintained at earth ground.



Complying with the usual warning to connect the power cable only to a properly grounded outlet is necessary but not sufficient for safe operation of a vacuum system with this or any similar high voltage producing product.

Verify that the vacuum port to which the Mini-Convectron Gauge is mounted is electrically grounded. It is essential for personnel safety as well as proper operation that the envelope of the gauge be connected to a facility ground. Use a ground lug on a flange bolt if necessary.

Vacuum gauges with compression fittings may be forcefully ejected if the vacuum system is pressurized.



Using the N₂ calibration to pressurize a vacuum system above about 1 Torr with certain other gases can cause dangerously high pressures which may cause explosion of the system. See Chapter 4 before using with other gases.



Warning – If used improperly, Mini-Convectron Gauges can supply misleading pressure indications that can result in dangerous overpressure conditions within the system.



Do not operate in an explosive atmosphere.

Do not operate the product in the presence of flammable gases or fumes.

Operation of any electrical instrument in such an environment constitutes a definite safety hazard.

Do not use the product to measure the pressure of explosive or combustible gases or gas mixtures. The sensor wire of the Mini-Convectron Gauge normally operates at only 125 °C, but it is possible that Controller malfunction can raise the sensor temperature above the ignition temperature of combustible mixtures.

Danger of explosion or inadvertent venting to atmosphere exists on all vacuum systems which incorporate gas sources or involve processes capable of pressurizing the system above safe limits.

It is the installer's responsibility to ensure that the automatic signals provided by the product are always used in a safe manner. Carefully check manual operation of the system and the set point programming before switching to automatic operation.

Where an equipment malfunction could cause a hazardous situation, always provide for fail-safe operation. As an example, in an automatic backfill operation where a malfunction might cause high internal pressures, provide an appropriate pressure relief device.



The fumes from solvents such as trichloroethylene, perchloroethylene, toluene, and acetone can be dangerous to health if inhaled. Use only in well ventilated areas exhausted to the outdoors. Acetone and toluene are highly flammable and should not be used near an open flame or energized electrical equipment.

Warranty information

Brooks Automation, Inc. provides an eighteen (18) month warranty from the date of shipment for new Granville-Phillips Products. The Brooks Automation, Inc. General Terms and Conditions of Sale provides the complete and exclusive warranty for Brooks Automation products. This document may be located on our web site at www.brooks.com, or may be obtained by contacting a Brooks Automation Customer Service Representative.

Service guidelines

Some minor problems are readily corrected on site. If the product requires service, please contact our Customer Service Department at 303-652-4400 for troubleshooting help over the phone.

If the module must be returned to the factory for service, request a Return Authorization (RA) from Brooks Automation / Granville-Phillips. Do not return products without first obtaining an RA. In some cases a hazardous materials document may be required. The Brooks Automation / Granville-Phillips Customer Service Representative will advise you if the hazardous materials document is required.

When returning equipment to Brooks Automation / Granville-Phillips, be sure to package the products to prevent shipping damage. Circuit boards and modules separated from the controller chassis **must** be handled using proper anti-static protection methods and **must** be packaged in anti-static packaging. Brooks Automation / Granville-Phillips will supply return packaging materials at no charge upon request. Shipping damage on returned products as a result of inadequate packaging is the Buyer's responsibility. *Before you return the module*, obtain an RA number by contacting Granville-Phillips customer service:

- Phone **1-303-652-4400** or **1-800-776-6543** within the USA.
- Phone **1-800-367-4887** 24 hours per day, seven days per week within the USA.
- Email co-csr@brooks.com
- For Global Customer Support, go to www.brooks.com, click on Contact Us, then click on Global Offices to locate the Brooks Automation office nearest you.

FCC verification

This equipment has been tested and found to comply with the limits for a Class A digital device, pursuant to Part 15 of the FCC Rules. These limits are designed to provide reasonable protection against harmful interference when the equipment is operated in a commercial environment. This equipment generates, uses, and can radiate radio frequency energy and, if not installed and used in accordance with this instruction manual, may cause harmful interference to radio communications. However, there is no guarantee that interference will not occur in a particular installation. Operation of this equipment in a residential area is likely to cause harmful interference in which case the user will be required to correct the interference at his own expense. If this equipment does cause harmful interference to radio or television reception, which can be determined by turning the equipment off and on, the user is encouraged to try to correct the interference by one or more of the following measures:

- Reorient or relocate the receiving antenna.
- Increase the separation between the equipment and the receiver.
- Connect the equipment into an outlet on a circuit different from that to which the receiver is connected.
- Consult the dealer or an experienced radio or television technician for help.

Canadian users

This Class B digital apparatus meets all requirements of the Canadian Interference-Causing Equipment Regulations.

Cet appareil numérique de la classe B respecte toutes les exigences du Règlement sur le matériel brouilleur du Canada.

1.1 Introduction

Unlike traditional thermocouple and Pirani gauges, Convectron gauges take advantage of heat loss due to convection cooling at higher pressures. This extends the range of accurate, repeatable vacuum measurements to atmosphere.

The Mini-Convectron module is a self-contained measurement device incorporating Convectron gauge technology and electronics in a compact modular design. The electronics and gauge are packaged in an all-metal package that provides a rugged enclosure and a high level of immunity to electrical noise. The Convectron gauge used in the module is field-replaceable.

The Mini-Convectron module is available in a variety of output configurations. This instruction manual is for use with a Mini-Convectron module with RS-485 output and dual process control relays. These adjustable setpoints allow control of valves, switches, alarm signals, or other controls.

Figure 1-1 Series 275 Mini-Convectron Module with RS-485 and dual process relays



1.2 Using this manual

This manual contains information on installation, operation, and trouble-shooting the Mini-Convectron module with RS-485 communications and dual process control relays. Following the instructions contained in the manual will ensure that this device will operate to specifications.

Within this manual:

- The term “module” refers to the entire Mini-Convectron module.
- The term “gauge” refers to the replaceable Convectron gauge.

Table 1-1 Specifications for the Mini-Convectron Module

Function	Description
Measuring range for N ₂	<ul style="list-style-type: none"> • 1 x 10⁻⁴ to 1000 Torr • Operation in the range of 1x10⁻⁴ to 1x10⁻³ Torr will require periodic verification of the zero by reducing system pressure to below 1 x 10⁻⁵ Torr • 1 x 10⁻⁴ to 1.300 mBar • 1.0⁻² to 130 KPa
Ambient operating temperature range	+4 to +50 °C
Gauge tube temperature compensation range	+15 to +50 °C
Bakeout temperature range (non-operating)	85 °C max.
Digital interface	RS-485, (2 wire)
Baud rate	300, 1200, 2400, 4800, 9600, 19,200 (default), 38,400
Data format	7 bits, even parity, 1 stop bit or 7 bits, odd parity, 1 stop bit or 8 bits, no parity, 1 stop bit.
Power required	<ul style="list-style-type: none"> • +11 Vdc to 26.5 Vdc at 0.12 Adc • Protected against reversals, transients or over-voltages • 2 watts maximum
Gauge tube internal volume	40 cc (2.5 cu in.)
Sensor wire	Gold plated tungsten
Setpoints (two)	<ul style="list-style-type: none"> • Single pole, double throw relay, silver alloy - gold clad contacts • UL rating: 1 A at 30 Vdc
Setpoint factory default	Disabled - set at 999 Torr
Connector	Input power, computer interface, and setpoints - 15 pin D male
Package	<ul style="list-style-type: none"> • Aluminum extrusion design with aluminum end plates • 4.5" long x 1.7" wide x 2.5" high plus gauge port and fitting

2.1 Receiving inspection

Domestic shipments

Inspect all material received for shipping damage.

Confirm that your shipment includes all material and options ordered. If materials are missing or damaged, the carrier that made the delivery must be notified within 15 days of delivery in accordance with Interstate Commerce regulations in order to file a valid claim with the carrier. Any damaged material including all containers and packing should be held for carrier inspection. Contact our Customer Service Department, 6450 Dry Creek Parkway, Longmont, Colorado 80503, 303-652-4400 if your shipment is not correct for reasons other than shipping damage.

2.2 International shipments

Inspect all material received for shipping damage. Confirm that your shipment includes all material and options ordered. If items are missing or damaged the carrier making delivery to the customs broker must be notified within 15 days of delivery.

If an airfreight forwarder handles the shipment and their agent delivers the shipment to customs the claim must be filed with the airfreight forwarder.

If an airfreight forwarder delivers the shipment to a specific airline and the airline delivers the shipment to customs the claim must be filed with the airline, *not* the freight forwarder.

2.3 Damaged material

Any damaged material, including all containers and packaging, should be held for carrier inspection. Contact our Customer Service Department, 6450 Dry Creek Parkway, Longmont, Colorado 80503, U.S.A. Telephone 303-652-4400 if your shipment is not correct for reasons other than shipping damage.

2.4 Important precautions for Mini-Convectron installation

The following precautions in the use and installation of the Mini-Convectron must be observed.

- It is recommended that the Mini-Convectron be installed with the port oriented vertically downward to ensure that no system condensates or other liquids collect in the gauge tube. The gauge tube axis must be horizontal if it is to be used at pressures above 1 Torr. Although the gauge tube will read correctly below 1 Torr when mounted in any position, erroneous readings will result at pressures above 1 Torr if the tube axis is not horizontal.
- Do not use a compression mount (quick connect) for attaching the Mini-Convectron to the system in applications resulting in positive pressures in the gauge tube. Positive pressures might blow the tube out of a compression fitting and damage equipment and injure personnel. Pipe thread or flange mounting systems should be used for positive pressure applications. In any case, the absolute pressure in the tube should not exceed 1000 Torr.
- Do not perform electrical continuity tests on the Mini-Convectron tube with instruments applying voltages in excess of 1 volt when the tube is at vacuum, or 5 volts when at atmospheric pressure. Exceeding these voltages will damage the sensing element.
- Keep the tube clean. Do not remove the mounting port cover until you are ready to install the tube.
- Do not mount the Mini-Convectron in a manner such that deposition of process vapors, upon the internal surfaces of the gauge tube, may occur through line-of-sight access to the interior of the gauge tube.
- Do not install the Mini-Convectron where high amplitudes of vibration are present. Excessive vibration will cause forced convection at high pressure giving erroneous readings.
- Do not bake the Mini-Convectron at temperatures exceeding 85 °C.
- Do not install the gauge tubes where they will be subject to corrosive gases such as mercury vapor or fluorine which will attack the gold plated sensor.
- For greatest accuracy and repeatability the Mini-Convectron tube should be located in a stable room temperature environment.
- All connections to the unit are to be made with shielded cable or cables. The shield or shields are to be connected to the connector shell.

2.5 Gauge tube construction

The transducer is a convection enhanced Pirani gauge providing rapid response, six-decades of pressure transduction, stable calibration, and good accuracy. The Pirani sensing element, R1 of the schematic of Figure 2-1, is one leg of a Wheatstone Bridge. A temperature compensating network, R2, forms the second leg of the bridge. The temperature sensitive component of this network is mounted inside the gauge tube envelope with the sensor. All other resistors of the bridge are mounted upon the exterior electrical feedthrough pins of the gauge tube. Pin 4 serves as an electrical terminal for construction of the compensating network, R2, but no connection is made therefrom to the controller.

All materials have been chosen for ultra high vacuum service, corrosion resistance and bakeability to 150 °C. The gauge tube envelope is type 304 stainless steel. All metallic joints in the envelope are welded. No solder is used within the envelope. The following materials are exposed to the vacuum: Type 304 stainless steel, Carpenter Alloy 52, Kovar, Kapton[®], gold plated tungsten and borosilicate glass.

Figure 2-1 Gauge tube schematic

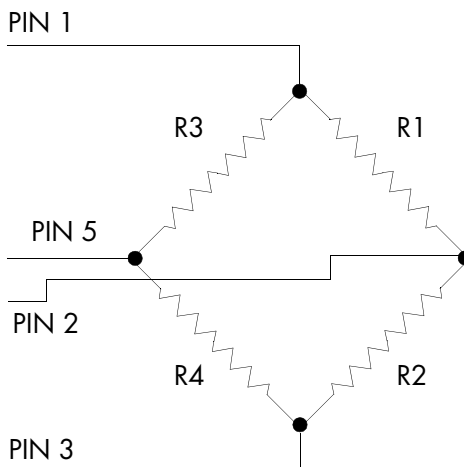

2.6 Mounting orientation and physical dimensions

Mounting Convector gauges

- Cleanliness pays. Keep the port cover in place until moments before installation.
- For proper operation above about 1 Torr, install Mini-Convector Modules with the gauge axis horizontal (see Figure 2-2). Although the gauge will read correctly below 1 Torr when mounted in any position, erroneous readings will result at pressures above 1 Torr if the gauge axis is not horizontal.
- Vibration causes convection cooling of the sensor and will result in high pressure readings. Mount Mini-Convector Modules where they will not vibrate excessively.
- Orient the gauge to prevent condensation of process vapors on the internal surfaces through line-of-sight access to its interior. If vapor condensation is likely, orient the port downward to help liquids drain out (see Figure 2-2).

Figure 2-2 Mini-Convector module installation

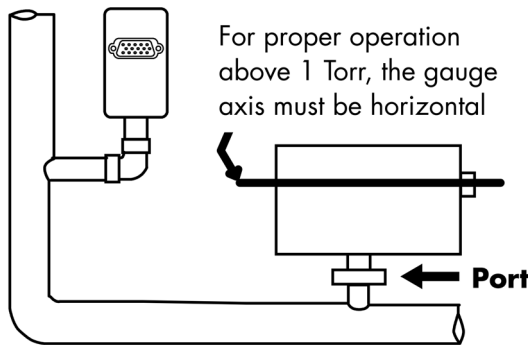

Environment

To minimize temperature effects, locate pressure gauges away from internal and external heat sources, in an area where the ambient temperature is reasonably constant.

Location Where you mount the gauge is critical to obtaining reliable pressure measurements. Long tubing or other constrictions can cause large errors in pressure readings. If you mount the gauge near the pump, the pressure in the gauge may be considerably lower than in the rest of the system. If you place the gauge near a gas inlet or other source of contamination, the pressure in the gauge may be much higher than in the rest of the system.

2.7 Grounding



When high voltage is present, all exposed conductors of a vacuum must be maintained at earth ground.

Under certain conditions, dangerously high voltage can be conducted through a gas directly to an ungrounded conductor almost as effectively as through a copper wire. The ability of an electric current to flow through a gas under certain circumstances poses a serious risk. Do not touch the exposed pins on any gauge installed on a vacuum system when high voltage is present.

The Convectron Gauge envelope may not be reliably grounded through its vacuum connection. For safety, you must either:

- Add a separate ground wire, or
- Shield the envelope to prevent human contact. Ground the gauge envelope by using a metal hose clamp on the gauge connected by a #12 AWG (minimum size) copper wire to the grounded vacuum chamber.

2.8 Gauge mounts

Compression mount/Quick connect

Do not use for positive pressure applications. The gauge may be forcefully ejected. The gauge port is designed to fit a standard 1/2 in. compression/quick connect mounting such as an Ultra-Torr[®] fitting. Insert the gauge tube port into the compression fitting and finger-tighten the press ring. A light film of vacuum grease, such as Apiezon[®], will ensure sealing.

1/8 NPT mount

Fits standard 1/8 NPT female fitting. Wrap the threads of the gauge port with Teflon[®] tape and hand tighten. Do not use a wrench or tool. Tighten only enough to achieve a seal.

NW or flange mount

The KF mounting system requires O-rings and centering rings between mating flanges. Tightening the wing nut will hold the flanges and the aluminum flange clamp together. Maximum pressure for this style of mounting system is 1000 Torr absolute.

ConFlat flange

To minimize the possibility of leaks with ConFlat® flanges, use high strength stainless steel bolts and a new, clean OFHC copper gasket. Avoid scratching the seal surfaces. To avoid contamination, do not use nonmetal gaskets.

Finger tighten all bolts. Use a wrench to continue tightening $\frac{1}{8}$ turn at a time in crisscross order, e.g., 1, 4, 2, 5, 3, 6, 4 until all flanges are in contact. After contact, further tighten each bolt about $\frac{1}{16}$ turn.

2.9 Dimensions

- Dimensions are in cm (in.).
- All dimensions are nominal. For tolerances, contact Brooks Automation, Inc./Granville-Phillips Customer Service Department.

Figure 2-3 Dimensions

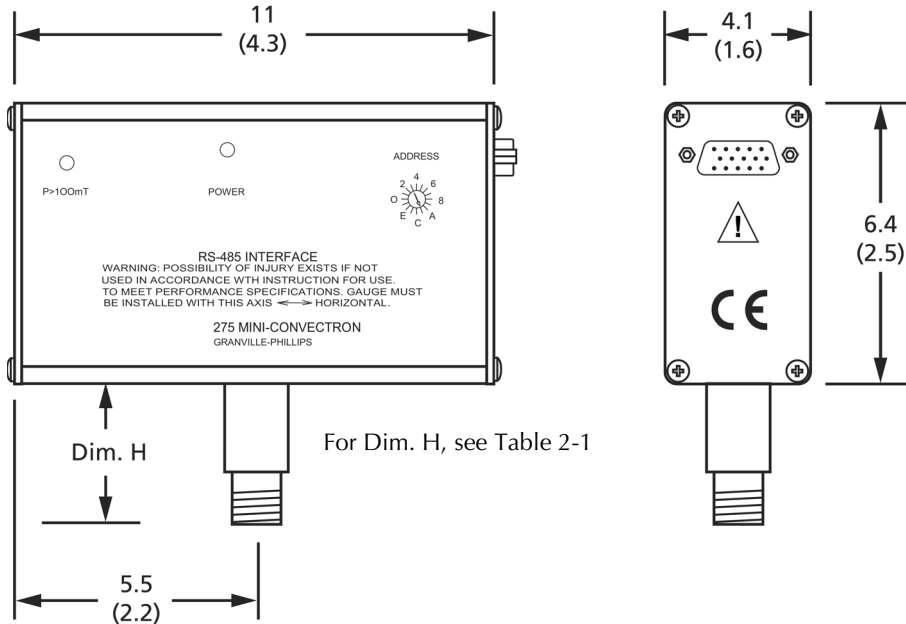

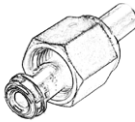



Table 2-1 Vacuum connections

Fitting	Description	Dimension H
 1/8 NPT pipe thread 1/2 inch compression fitting	1/8 NPT pipe thread 1/2 inch quick connect/weld	2.5 cm (1.0 in.)
 VCR-type female fitting	1/4 inch VCR-type female fitting 1/2 inch VCR-type female fitting	3.0 cm (1.2 in.) 3.9 cm (1.4 in.)
 ConFlat-type flange	1.33 inch (NW16CF) ConFlat-type 2.75 inch (NW35CF) ConFlat-type	3.8 cm (1.5 in.) 3.8 cm (1.5 in.)
 KF flange	NW16KF flange NW25KF flange NW40KF flange	3.1 cm (1.2 in.) 3.1 cm (1.2 in.) 3.1 cm (1.2 in.)

2.10 I/O connector wiring

The 15 pin high density "D" type connector has the pin assignments shown in Figure 2-4 and listed in Table 2-2.

Figure 2-4 15-pin D type connector pins

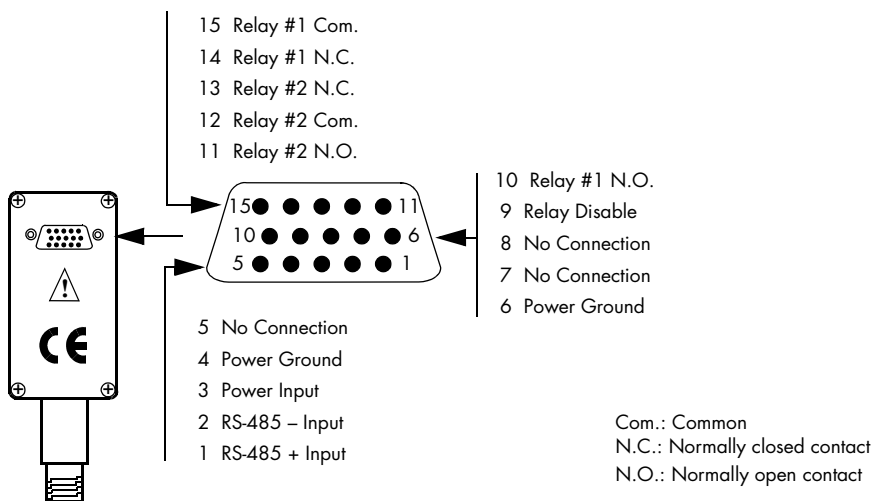

Table 2-2 D type connector pin descriptions

Pin number	Function
Pin 1	RS-485 + input
Pin 2	RS-485 - input
Pin 3	Input power +11 Vdc to +26.5 Vdc
Pin 4	Input power ground
Pin 6	Input power ground
Pin 10	Setpoint 1 N.O.
Pin 11	Setpoint 2 N.O.
Pin 12	Setpoint 2 common <ul style="list-style-type: none"> • Factory default for setpoint 2 • De-energized $P \leq 500T$ • Energized $P \geq 550T$
Pin 13	Setpoint 2 N.C.
Pin 14	Setpoint 1 N.C.
Pin 15	Setpoint 1 common <ul style="list-style-type: none"> • Factory default for setpoint 1 • Energized $P \leq 5mT$ • De-energized $P \geq 8mT$

2.11 RS-485 network wiring

Connection between multiple controllers can easily be made by daisy chaining gauge controllers together with the signal from the host computer going into one connector then out the other to another gauge controller.

- The maximum total cable length is 4,000 ft.
- No more than 32 devices can be connected to one RS-485 communications line.

When an RS-485 network is in an idle state, all nodes are in listen (receive) mode. Under this condition there are no active drivers on the network. To maintain the proper idle voltage state, bias resistors must be applied to force the data lines to the idle condition. Figure 2-5 illustrates the placement of bias resistors on a host computer for typical 5 volt and 24 volt systems.

Figure 2-5 Bias resistor placement on host controller

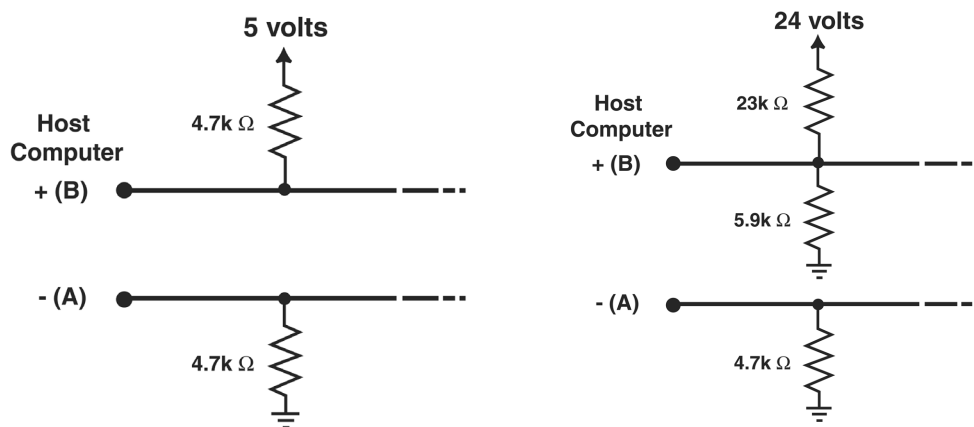

Chapter 3 Operation

3.1 Power

The Mini-Convectron is in operation anytime that the +11 Vdc to +26.5 Vdc input voltage is applied. The sensor of the gauge tube runs at a temperature of approximately 120 °C above ambient, and gauge tube life is not affected by hours of operation.

3.2 Front panel features

Table 3-1 Front panel features

Front panel feature	Function
P > 100 mTorr Indicator	A red light emitting diode is used as a rough pressure indicator. The LED will be OFF below 100 milliTorr and gradually turn on as pressure increases.
Power indicator	A green light emitting diode is on when power is applied and microprocessor is working. LED blinks if microprocessor is not working. LED OFF when no power applied.
Address selector	Rotate pointer to desired RS-485 address. The address switch value is added to the programmed offset address (SA command).

Figure 3-1 Front panel indicators and address selector



3.3 Digital communications

Table 3-2 Default settings

Function	Default setting
Baud rate	19.2 Kbaud
Data format	ASCII 8 databits, 1 stopbit, no parity
Address	01

Syntax/address overview

A command from the host must include a start character, address, data, and terminator:

(start character)(address)(data)(terminator)

- The start character is "#"
- The address is two ASCII digits representing the Hex address of the module.
Example: 0F is address 15
- The data field is explained in the command descriptions. All command examples are shown with an address of 01. If the address is changed, both the command and response will have the new address instead of 01. All alpha characters can be upper or lower case. The response is in upper case.
- The terminator character is "control" M or Hex 0D for a carriage return "CR", and "_" space signified below by:
_ = space
CR = carriage return.

All data fields responses will contain 13 characters, uppercase alpha characters. The commands are of various character lengths

A response of ?01_SYNTAX_ER CR is caused by an incorrect character string sent from the host, or when the syntax is not recognized by the module.

RS-485 address switch settings

The address switch sets the base module address. The address switch ranges from 0 to 15 (00 Hex — 0F Hex). There is an address offset, set by the "SA" command that can set additional address offsets through the RS-485 interface.

Baud rate, stop bit and parity

The baud rate, stop bit setting and parity setting are all changed through the RS-485 interface. The new settings take effect when the power is cycled, or when an "RST" command is sent over the interface. The Baud rate, stop bit, and parity can be set to the factory default values using the "FAC" RS-485 command.

Command set

Table 3-3 Summary of RS-485 commands

Command	Description	Command type	Data returned
RD	Read pressure	Read	Pressure
SA	Set address offset	Write	Confirm
TS	Set span	Read/Write	Confirm or state
TZ	Set zero	Read/Write	Confirm or state
SH	Set setpoint 2	Write	Confirm
SL	Set setpoint 1	Write	Confirm
RH	Read setpoint 2	Read	Setpoint 2 On value
RL	Read setpoint 1	Read	Setpoint 1 On value
VER	Read firmware revision	Read	Firmware revision
FAC	Set factory default	Write	Confirm
SB	Set baud rate	Write	Confirm
SPN	Set parity to 8 bits, none	Write	Confirm
SPO	Set parity to 7 bits, odd	Write	Confirm
SPE	Set parity to 7 bits, even	Write	Confirm
SF	Set A/D sampling frequency	Write	Confirm
RST	Reset module	Write	None
SU	Set unit of measure	Write	Confirm
RU	Read unit of measure	Read	Unit of measure

RD

ReaD Convector pressure response

Example:

From host: #01RD CR
From Mini-Convector: *01_9.34E-02 CR

Notes:

__ = space, CR = carriage return. ASCII string representing pressure in scientific notation.

Three significant digits except in 10^{-3} Torr range with 2 significant digits and a zero filler, 10^{-4} range with 1 significant digit with 2 zero fillers.

While at vacuum, the readout may be -0.00E-00. This occurs when the transducer voltage at vacuum has drifted lower than that set by the "TZ" command. The number received at vacuum will fluctuate under normal operation but if it reads negative consistently, calibration may be required. See .

Another possible response from RD is ?01_DEF_SNSR. There are three possible causes for this response:

1. Defective transducer, see Chapter 5.
2. Pressure much higher than 1000 Torr.
3. Gases other than nitrogen in system. Atmosphere pressure of helium will cause this response.

SA

Set Offset Address

Example:

From host: #01SA20 CR
From Mini-Convector: *01_PROGM_OK CR

Notes:

The address selector setting is added to this value. Example: address selector is set at 2 and offset value is 20 then the module address is 22. The operating address will not change until the power is cycled or RST is sent.

TS	Set span (typically at atmospheric pressure)	
	Use scientific notation.	
Example:	From host: From Mini-Convectron:	#01TS7.60E+02 CR *01_PROGM_OK CR
Possible responses:	*01_HI_ATM_V CR	Transducer output voltage is higher than it should be. Actual pressure may be higher or there may be tube contamination which may cause readout error to increase between TZ and TS settings. If ?01_OFST_LIM CR was received while setting TZ, this response may occur.
	*01_LO_ATM_V CR	Transducer output voltage is lower than it should be. Similar to HI_ATM_V.
	?01_GAIN_LIM CR	Gain programmed at limit. Readout errors will occur even at TS setting.
	?01_DEF_SNSR CR	Sensor defect, no change in programming, see maintenance section.
	?01_RANGE_ER CR	Command error, TS must be set above 399 Torr. No change in programming.
Notes:	Do this only at higher pressures. If performed at vacuum, an error message response will occur. The change occurs as soon as the function is performed.	

TZ	Set zero (at or near vacuum)	
	Use scientific notation or 0.	
Example:	From host:	#01TZ0 CR
	From Mini-Convector:	*01_PROGM_OK CR
	From host:	#01TZ1.00E-02 CR
	From Mini-Convector:	*01_PROGM_OK CR
Possible responses:	*01_HI_VAC_V CR	Transducer output voltage is higher than it should be. Actual pressure may be higher or there may be tube contamination which may cause readout error to increase between TZ and TS settings.
	*01_LO_VAC_V CR	Transducer output voltage is lower than it should be. Similar to HI_VAC_V.
	?01_OFST_LIM CR	Offset programmed at limit. Readout errors will occur even at TZ setting.
	?01_DEF_SNSR CR	Sensor defect, no change in programming, see maintenance section.
	?01_RANGE_ER CR	Command error, TZ must be set below 1×10^{-1} Torr. No change in programming.
Notes:	Do this only at lower pressures, will respond with error message if done near atmosphere. This change occurs as soon as the function is performed.	

SH Set setpoint 2 trip point

Example: From host: #01SH+1.00E-01 CR
 From Mini-Convectron: *01_PROGM_OK CR

From host: #01SH-2.00E-01 CR
 From Mini-Convectron: *01_PROGM_OK CR

Notes: The above example will turn on or energize the relay when the pressure is less than 1.00E-01 TORR, for nitrogen.

The relay will turn off when the pressure goes above 2.00E-01 TORR.

The – value from the host sets the relay OFF point and the + value set the relay ON point.

The above example turns on the relay below the setpoint.

To turn on the relay above the setpoint, the – value must be lower than the + value.

The minimum hysteresis is 10 mV of Convectron bridge voltage. This corresponds to 10 TORR at atmosphere and 1 mTorr near vacuum. In the example here, if the host sets the OFF point to -1.01E-01 TORR, the ON point will automatically change to 9.80E-02. The response will be '*01 +MIN HYS'.

SH+ SH- may be set for the same pressure. If this is done, the second SH_ command will determine the relay logic. SH+ sent last will generate a +MIN HYS response and the relay will energize BELOW the setpoint. SH- sent last will generate a -MIN HYS response and the relay will energize ABOVE the setpoint.

SL Set setpoint 1 trip point

Example: From host: #01SL+1.00E-01 CR
 From Mini-Convectron: *01_PROGM_OK CR

From host: #01SL-2.00E-01 CR
 From Mini-Convectron: *01_PROGM_OK CR

Notes: Same function as SH for setpoint 1.

RH Read setpoint 2 trip point

Example: From host: #01RH+CR
 From Mini-Convectron: *01_9.80E-02 CR

Notes: RH+ reads setpoint ON value, value begins with a space. RH- reads setpoint OFF value, value begins with a minus sign.

RL Read setpoint 1 trip point

Example: From host: #01RL-CR
From Mini-Convectron: *01-9.80E-02 CR

Notes: RL+ reads setpoint ON value, RL- reads setpoint OFF value. Same function as RH for setpoint 1.

VER Read Mini-Convectron firmware version

Example: From host: #01VER CR
From Mini-Convectron: *01_12997-00

Notes: In this example, 12997 is the Granville-Phillips/Brooks Automation internal part number, 00 is the revision. Larger revision numbers indicate newer versions of firmware.

FAC Set factory default

Example: From host: #01FAC CR
From Mini-Convectron: *01_PROGM_OK CR

Notes: This can be used when a Mini-Convectron is not responding properly. Cycle power or send RST after doing this function. FAC will cause default communication and transducer parameters to be programmed:

- Base Address = 01
- Zero and span are set to default values
- A/D sample frequency is set to 60 Hz
- Baud rate = 19200
- Data format = 8 bits, no parity, 1 stop bit

SB Set baud rate

Example: From host: #01SB2400 CR
From Mini-Convectron: *01_PROGM_OK CR

Notes: Will continue to operate at old baud rate until power is cycled or RST command is sent. Max. baud rate is 38.4K. If you set baud rate to an odd value like 2234, it will actually operate at that non-standard speed. Be careful, you may need to set the program jumper if the unit stops responding.

SPN Set parity to 8 bits, none

Example: From host: #01SPN CR
From Mini-Convectron: *01_PROGM_OK CR

Note: Will continue to operate at old format until power is cycled, or RST command is sent.

SPO Set parity to 7 bits, odd

Example: From host: #01SPE CR
From Mini-Convectron: *01_PROGM_OK CR

Note: Same as SPN.

SPE Set parity to 7 bits, even

Example: From host: #01SPE CR
From Mini-Convectron: *01_PROGM_OK CR

Note: Same as SPN.

SF Set frequency

Example: From host: #01SF10 CR
From Mini-Convectron: *01_PROGM_OK CR

Notes: This is the frequency in Hz that the A/D samples the transducer voltage. This can be programmed to reject line frequency noise or noise caused by mechanical vibration. The allowable sample frequency range is 2 to 120 Hz.

The pressure update rate is dependent on sample frequency:
Pressure update = sample frequency/6.

For a sample frequency of 10 Hz, an RD can be performed at any speed but the pressure readout will change only once every 600 MS.

The TZ and TS calibration may need to be changed if this function is used.

RST Reset module

Example: From host: #01RST CR

Notes: The RST command will reset the module as if the power had been cycled. RST has no response. Communication is re-enabled in 2 seconds.

SU

Set pressure units of measure

Example: From host: #01SUT CR
From Mini-Convectron: *01_PROGM_OK CR

Note: The last character in the command string determines the unit of measure where M = mBar, P = pascal, and T = Torr.

RU

Read pressure units of measure

Example: From host: #01RU CR
From Mini-Convectron: *01 MBAR CR, or
*01 PASCAL CR, or
*01 TORR CR

Command – response timing

The speed of the response from the Mini-Convectron varies depending on the type of command being carried out.

- The Mini-Convectron will shut off its driver H = 80US after sending data to host.
- The times indicated below are approximate.

RX, TX timing

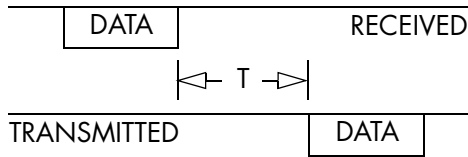

Baud rate	T
38400	3.3 ms
19200	3.9 ms
9600	5.1 ms
4800	7.5 ms
2400	13 ms
1200	22 ms
300	79 ms

Command type	Time added to T
FAC	105 MS
RD	0 MS
RST	No response
All others	17 MS

Chapter 4 Calibration

4.1 Calibration

Each Mini-Convector gauge tube is individually calibrated for N₂ and temperature compensated prior to leaving the factory. Each controller is individually calibrated to provide accurate readout of N₂ or air pressure; therefore, initial calibration should not be necessary. See page 40 for use with gases other than N₂ and air. If the tube becomes contaminated or does not read correctly, the Mini-Convector can be calibrated by performing the following steps. Always perform vacuum adjust before atmosphere adjust. Atmosphere adjust will not effect vacuum setting but vacuum adjust will effect atmosphere setting.

Vacuum adjust

1. Evacuate the system.
2. If you know the pressure is less than 1×10^{-4} Torr, send TZ0 or TZ0.00E-00 and the Mini-Convector will be zeroed. If the base pressure is between 1×10^{-4} Torr and 1×10^{-1} Torr, use another gauge or pump specs to set TZ. Example: You know that your pump will go down to 1×10^{-2} Torr, so send TZ1.00E-02.

Atmosphere adjust

1. Allow the system pressure to rise to atmospheric pressure of air.
2. Use Table 4-1 to determine atmospheric pressure in torr for your area. For sea level, send TS7.60E+02.

Table 4-1 Altitude and atmospheric pressure

Altitude in feet above sea level	Pressure in Torr (N ₂ or air)
0	760
1000	733
2000	707
3000	681
4000	656
5000	632
6000	609
7000	586
8000	564
9000	543
10,000	523

4.2 Use with gases other than N₂ and air

Before using the Mini-Convectron gauge to measure the pressure of other gases make certain the TS adjustment is correctly set for air.

It is important to understand that the indicated pressure on a Mini-Convectron gauge depends on the type of gas in the tube, and on the orientation of the tube axis as well as on the gas pressure in the tube. Mini-Convectron gauges are supplied calibrated for N₂ within the accuracy of the instrument. With certain safety precautions, the Mini-Convectron gauge may be used to measure pressure of other gases.

Mini-Convectron gauge tubes are thermal conductivity gauges of the Pirani type. These gauges transduce gas pressure by measuring the heat loss from a heated sensor wire maintained at constant temperature. For gases other than N₂ and air the heat loss is different at any given true pressure and thus the indicated reading will be different.

Figure 4-1, Figure 4-2, and Figure 4-3 show the true pressure vs. indicated pressure for eleven commonly used gases. The following list will help to locate the proper graph:

Table 4-2 Pressure vs. indicated N₂ pressure curve

Figure	Pressure range and units	Gases
Figure 4-1	10 ⁻⁴ to 10 ⁻¹ Torr	All
Figure 4-2	10 ⁻¹ to 1000 Torr	Ar, CO ₂ , CH ₄ , Freon 12, He
Figure 4-3	10 ⁻¹ to 1000 Torr	D ₂ , Freon 22, Kr, Ne, O ₂

Note that 1 mbar = 100 pascal, so the mbar charts may be used for pascal units by multiplying the values on the axes by 100.

A useful interpretation of these curves is, for example, that at a true pressure of 2 x 10⁻² Torr of CH₄ the heat loss from the sensor is the same as at a pressure of 3 x 10⁻² Torr of N₂ (see Figure 4-1). The curves at higher pressure vary widely from gas to gas because the thermal losses at higher pressures are greatly different for different gases.

The Mini-Convectron gauge tube utilizes convection cooling to provide resolution superior to any other thermal conductivity gauge near atmospheric pressure of N₂ and air. Because convection effects are geometry dependent, the true pressure vs indicated pressure curves for the Mini-Convectron gauge tube are likely to be much different from curves for heat loss tubes made by others. Therefore, it is not safe to attempt to use calibration curves supplied by other manufacturers for their gauges with the Mini-Convectron nor is it safe to use curves for the Mini-Convectron gauge with gauges supplied by other manufacturers.

If you must measure the pressure of gases other than N₂ or air, use Figure 4-1, Figure 4-2, or Figure 4-3 to determine the maximum safe indicated pressure for the other gas as explained below.

Example 1: Maximum safe indicated pressure

Assume a certain system will withstand an internal pressure of 2000 Torr or 38.7 psia. For safety, limit the maximum internal pressure to 760 Torr during backfilling. Assume you want to measure the pressure of argon. On Figure 4-2 locate 760 Torr on the left hand scale, travel to the right to the intersection with the argon (Ar) curve and then down to an indicated pressure of 24 Torr (N₂ equivalent). Thus in this hypothetical situation the maximum safe indicated pressure for argon is 24 Torr.

For safety, place a warning label on the instrument which under the assumed conditions would read "DO NOT EXCEED 24 TORR FOR ARGON."

Example 2: Indicated to true pressure conversion

Assume you want to determine the true pressure of argon in a system when the Convector is indicating 10 Torr. On Figure 4-2, read up from 10 Torr (N₂ equivalent) indicated pressure to the argon curve and then horizontally to the left to a true pressure of 250 Torr. Thus 250 Torr argon pressure produces an indication of 10 Torr (N₂ equivalent).

Example 3: True to indicated pressure conversion

Assume you want to set a process control setpoint at a true pressure of 20 Torr of CO₂. On Figure 4-2, locate 20 Torr on the true pressure scale, travel horizontally to the right to the CO₂ curve and then down to an indicated pressure of 6 Torr (N₂ equivalent). Thus the correct process control setting for 20 Torr of CO₂ is 6 Torr (N₂ equivalent).

Example 4: True to indicated pressure conversion

Assume you want to obtain a helium pressure of 100 Torr in the system. On Figure 4-3, locate 100 Torr on the left hand scale, travel horizontally to the right to attempt to intersect the He curve. Because the intersection is off scale it is apparent that this true pressure measurement requirement for helium exceeds the capability of the instrument.

For gases other than those listed, the user must provide accurate conversion data for safe operation. The Mini-Convector gauge is not intended for use above 1000 Torr true pressure.

Figure 4-1 Reading true pressure values, 10^{-4} to 10^{-1} Torr

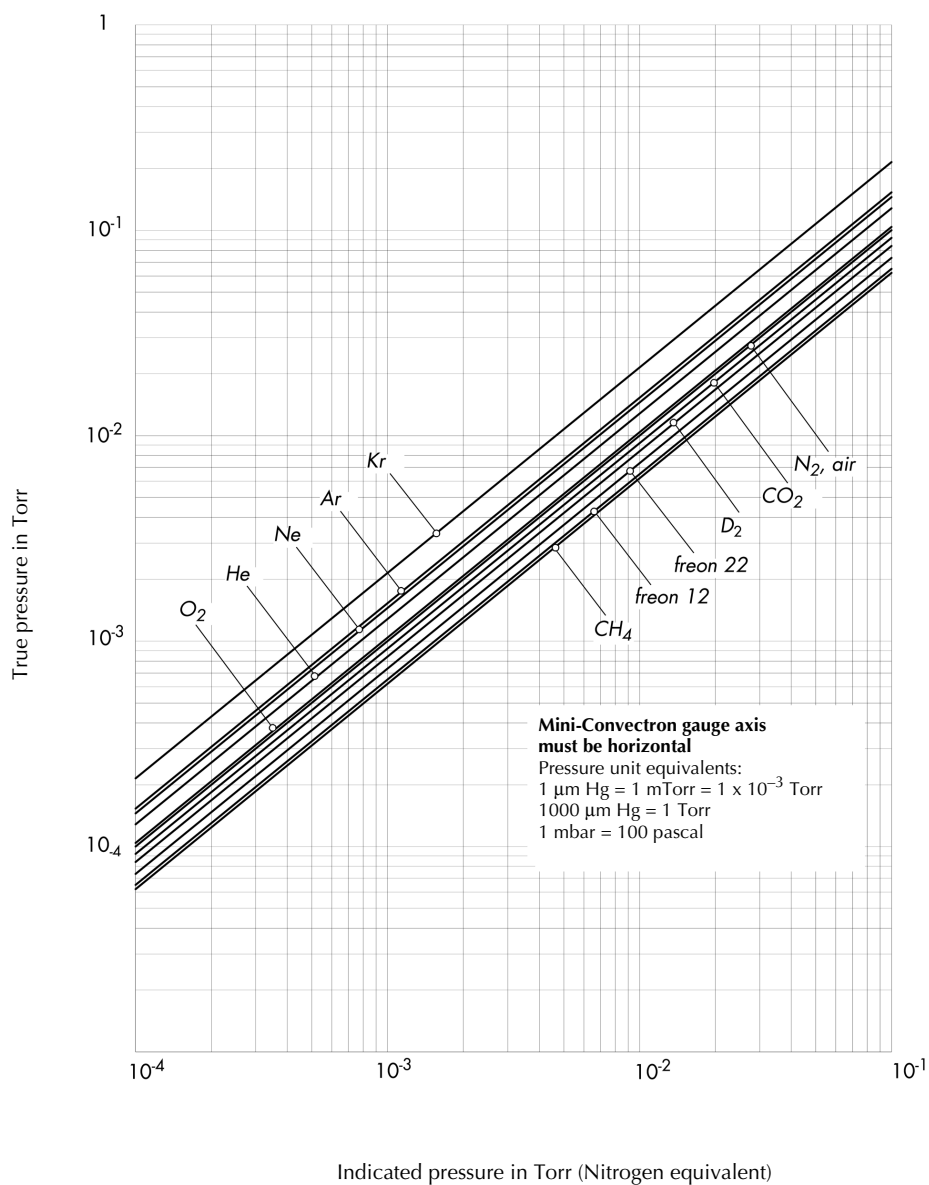

Figure 4-2 Reading true pressure values, 10^{-1} to 1000 Torr

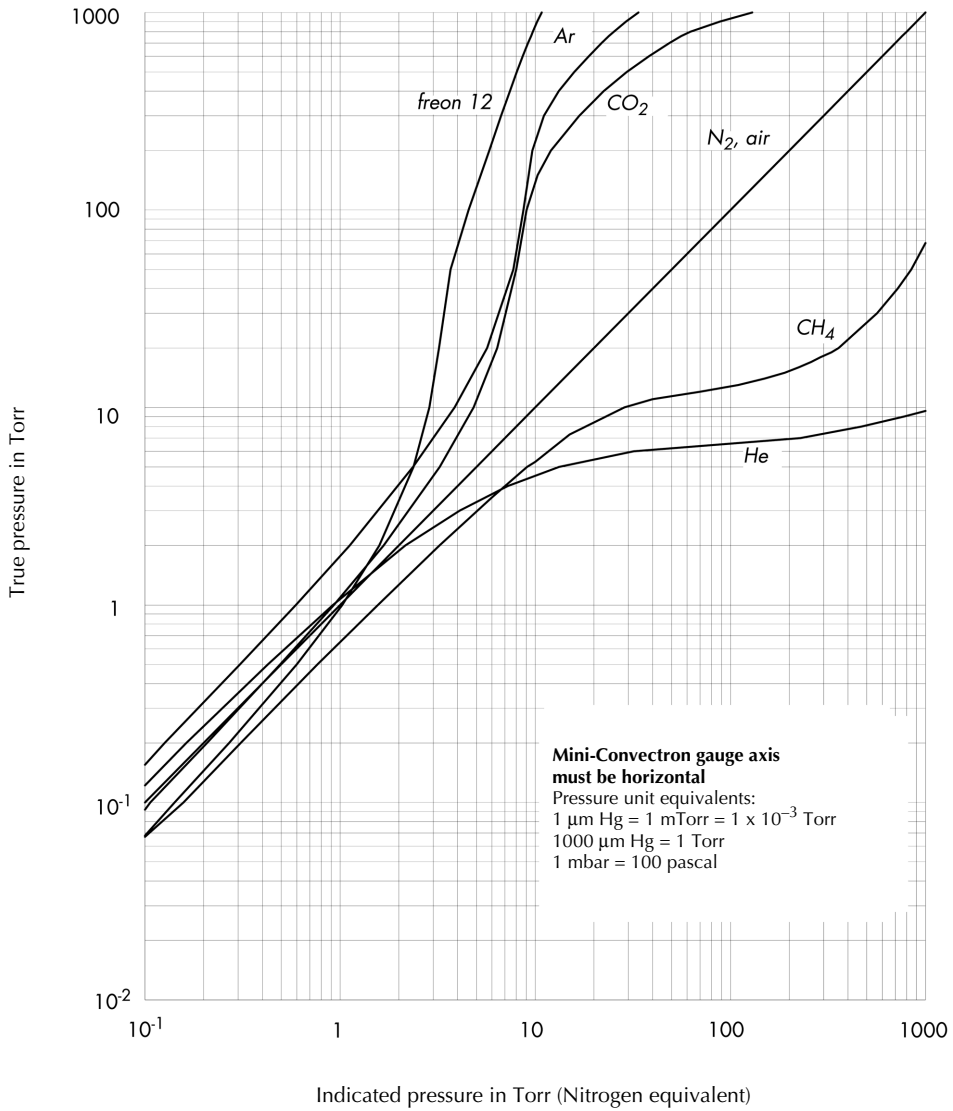
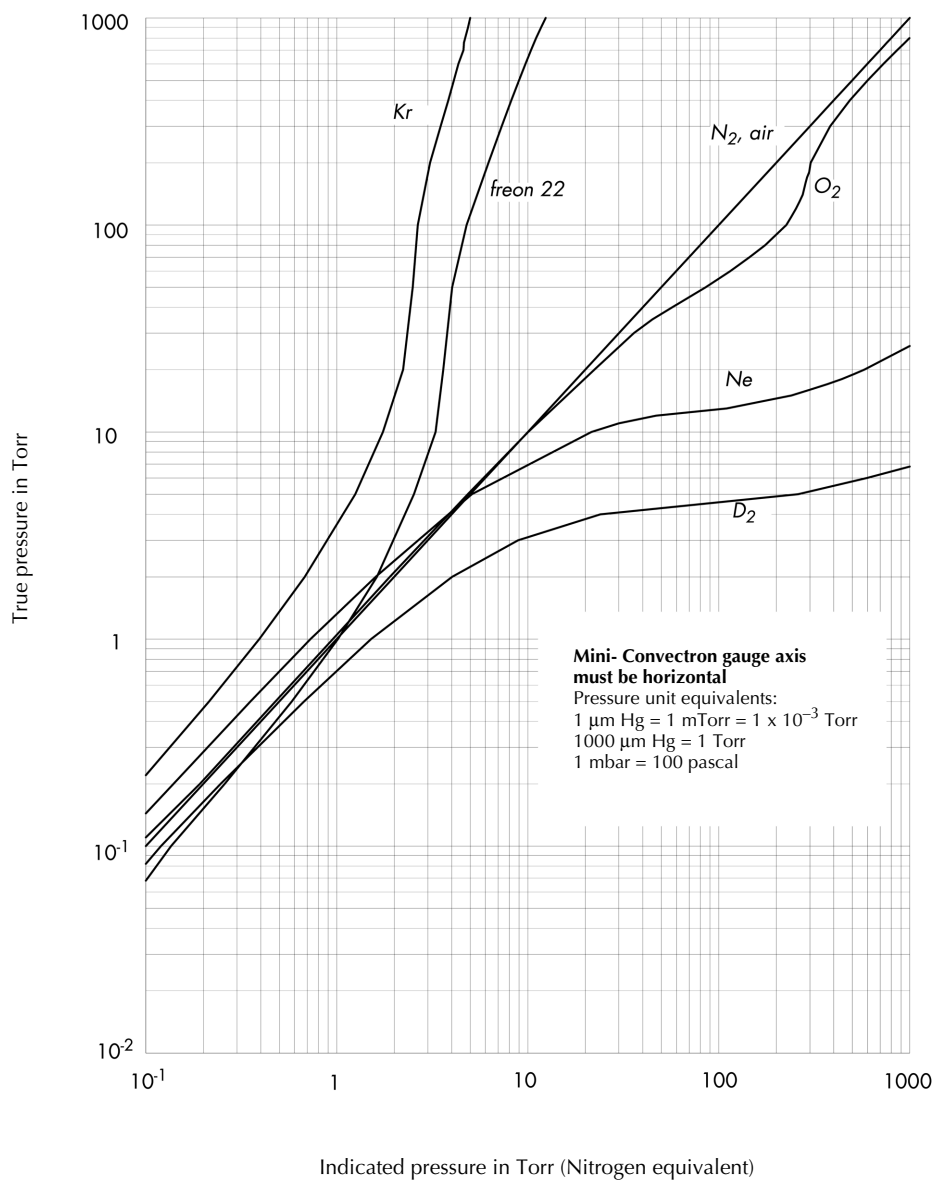

Figure 4-3 Reading true pressure values, 10^{-1} to 1000 Torr



Chapter 5 Maintenance

5.1 General information

Although the Mini-Convectron was designed using as many commonly available components as possible, thus allowing easy service, it is still recommended that only qualified technical personnel attempt repairs.

If difficulties are encountered during use of your Mini-Convectron, the following list of symptoms and possible causes, along with the schematics, can prove useful in quickly getting back into operation.

If the prescribed remedies do not correct the troubles, or if additional assistance or special parts are required, contact the Technical Service Department, Granville-Phillips/Brooks Automation, 6450 Dry Creek Parkway, Longmont, Colorado, 80503. Telephone: 303-652-4400. Repairs properly made with equivalent electronic parts and rosin core solder, which do not damage other portions of the unit, do not represent a violation of the warranty.

Check Table 5-1 for the observed symptoms. This listing of symptoms and possible causes is not complete, but should be sufficient to solve most problems. *All possible causes of failure should be thoroughly explored before attempting any repair.*

5.2 Guidelines

Since the Mini-Convectron contains static-sensitive electronic parts, the following precautions must be followed when troubleshooting:

1. Use a grounded, conductive work surface.
2. Use static dissipative envelopes to store or ship printed circuit boards.
3. *Do not* handle the printed circuit board more than absolutely necessary, and only when wearing a ground strap.
4. *Do not* use an ohmmeter for troubleshooting. Rely on voltage measurements.
5. Use grounded-type soldering irons only.

5.3 Mini-Convectron disassembly

For most troubleshooting procedures it will be required that the printed circuit board and gauge tube be removed from the enclosure. To accomplish this proceed as follows:

1. Remove the eight screws holding on the two end plates of the module.
2. Remove the top and bottom chassis members leaving the PC board assembly with the gauge tube.
3. To remove the gauge tube from the PC board simply unplug from the four sockets on the board.
4. For assembly, reverse this procedure. Make sure the PC boards are in the slots of the chassis.

5.4 Symptoms and possible causes

Table 5-1 General symptoms/possible causes

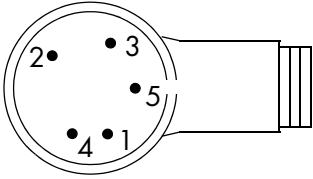
Symptom	Possible causes
No power indication	No input power. Verify that there is +11 Vdc to +16 Vdc at pin 3 of the I/O connector with respect to pin 4.
Bridge analog output voltage reads less than +0.22 Vdc or greater than +10 Vdc	<p>1. Gauge tube failure. Test for gauge tube failure. Measure the resistance between the following terminals with the gauge tube at atmospheric pressure and an ohmmeter which cannot apply more than 10 mA.</p>  <ul style="list-style-type: none"> • Pins 1 to 2: 18 to 23 ohms • Pins 2 to 3: 50 to 60 ohms • Pins 1 to 5: 175 to 190 ohms <p>If the resistance from pins 1 to 2 reads about 800 ohms, the sensor wire in the gauge is broken. Replace the gauge tube.</p> <p>2. Bridge amplifier failure. All of this circuitry is located on the small PC board that the gauge tube plugs into. Check for input power to this board across the two outside fingers of the small board where it is soldered into the large board. Check that the bridge output voltage between the middle finger and the bottom finger is approximately 6 Vdc with the gauge tube at atmosphere.</p>



The fumes from solvents can be dangerous to your health if inhaled and they should be used in well-ventilated areas exhausted to the outdoors. Acetone and toluene are highly flammable and should be used away from open flame or electrical equipment.

Table 5-1 General symptoms/possible causes (continued)

Symptom	Possible causes
Readout cannot be calibrated to the specified value using TS or TZ commands	<p>1. Gauge tube contaminated with material from vacuum system. Clean gauge tube. If not effective, replace gauge tube.</p> <p>Cleaning:</p> <p>Prior to cleaning, the gauge tube must be removed from the electronics as described on page 47. Cleaning solvents can damage electronic components or the enclosure.</p> <p>When the small sensor wire is contaminated with oil or other films, its emissivity or its diameter may be appreciably altered and a change of calibration will result. Cleaning with trichloroethylene, perchloroethylene, toluene, or acetone is possible but it must be done very carefully so as not to damage the sensor.</p> <ol style="list-style-type: none"> a. Hold the gauge with the main body horizontal and the port projecting upward at a 45° angle. b. Slowly fill the port with solvent using a standard wash bottle with the spout inserted in the port to the point where it touches the screen. Let the solvent stand in the gauge for at least ten minutes. <i>Do not shake the gauge.</i> Shaking the gauge with liquid inside can damage the sensor wire. c. To drain the gauge, position it horizontally with the port facing downward. d. Allow the gauge to dry overnight with the port vertically downward and uncapped. Before re-installing the gauge on the system, be certain no solvent odor remains. <p>2. The gold plating on sensor has been attacked by a gas such as fluorine or mercury vapor, changing its emissivity and/or resistance. Replace the gauge tube. Cleaning cannot solve this problem.</p>
Readout indicating a pressure in system vastly different than being observed by supporting gauges	Gas composition on system not what user believes it to be. This can be caused by selective gas pumping, process in use, outgassing of product, etc. Determine gas composition and calibrate accordingly.

5.5 **Returning a
Mini-Convector module
for service**

If the module must be returned to the factory for service, request a Return Authorization (RA) from Brooks Automation / Granville-Phillips. Do not return products without first obtaining an RA. In some cases a hazardous materials document may be required. The Brooks Automation / Granville-Phillips Customer Service Representative will advise you if the hazardous materials document is required.

When returning equipment to Brooks Automation / Granville-Phillips, be sure to package the products to prevent shipping damage. Circuit boards and modules separated from the controller chassis must be handled using proper anti-static protection methods and must be packaged in anti-static packaging. Brooks Automation / Granville-Phillips will supply return packaging materials at no charge upon request. Shipping damage on returned products as a result of inadequate packaging is the Buyer's responsibility. *Before you return the module*, obtain an RA number by contacting Granville-Phillips customer service:

- Phone **1-303-652-4400** or **1-800-776-6543** within the USA.
- Phone **1-800-367-4887** 24 hours per day, seven days per week within the USA.
- Email *co-csr@brooks.com*
- For Global Customer Support, go to www.brooks.com, click on Contact Us, then click on Global Offices to locate the Brooks Automation office nearest you.

Index

- A**
 - Address selector **27**
 - Ambient operating temperature range **16**
 - Atmosphere adjust **40**
- B**
 - Baud rate **16, 28, 34**
- C**
 - Calibration **39**
 - Command set **29**
 - Connector, 15-pin "D" type **23**
- D**
 - Damage requiring service **9**
 - Dimensions **22**
 - Disassembly **47**
- E**
 - Environment for installation **20**
- F**
 - 15-pin "D" type connector **23**
 - FCC verification **14**
 - Firmware version **34**
 - Frequency **35**
 - Front panel **27**
- G**
 - Gauge tube construction **19**
 - Ground test **11**
 - Grounding **21**
- I**
 - I/O connector wiring **23**
 - Indicated pressure **40**
 - Installation
 - environment **20**
 - grounding **21**
 - location **21**
 - Mini-Convectron module **20**
 - mounting **21**
 - position **20**
- L**
 - Location for installation **21**
- M**
 - Maintenance
 - returning a damaged module **50**
 - Mini-Convectron module
 - mounting gauges
 - 1/8 NPT mount **21**
 - compression mount/quick connect **21**
 - ConFlat flange mount **22**
 - NW16KF flange mount **21**
 - Mounting gauges **21**
 - 1/8 NPT mount **21**
 - compression mount/quick connect **21**
 - ConFlat flange mount **22**
 - NW16KF flange mount **21**
 - Mounting orientation **20**
- O**
 - Offset address **30**
 - Overpressure **10**
- P**
 - P > 100 mTorr indicator **27**
 - Parity **35**
 - Parity settings **28**
 - Physical dimensions **22**
 - Pins in "D" type connector **23**
 - Power **27**
 - Power indicator **27**
 - Pressure
 - reading true values **43–45**
 - true versus indicated **43–45**
 - Pressure response **30**
 - Pressure units of measure **36**
- R**
 - Reset **35**
 - Response timing **36**
 - Returning a damaged module **50**
 - RS-485 address switch settings **28**
 - RS-485 commands **29**

RS-485 wiring **24**

S

Safety **7**

 damage requiring service **9**

 instructions **7**

Service guidelines **13**

Setpoint 1 **33, 34**

Setpoint 2 **33**

Span **31**

Stop bit settings **28**

Syntax/address overview **28**

System ground **11**

T

Troubleshooting **48**

U

Units of measure **36**

V

Vacuum adjust **39**

W

Warranty **13**

Series 275

Granville-Phillips® Mini-Convectron® Module with RS-485 and Dual Process Relays



6450 Dry Creek Parkway

Longmont, CO 80503 USA

Phone: 1-303-652-4400

15 Elizabeth Drive

Chelmsford, MA 01824 USA

Phone: 1-978-262-2400

Worldwide Customer Service/Support - 24/7

Phone: 1-800-367-4887

To obtain a copy of this instruction manual online,
visit our website at www.brooks.com

(Adobe® Reader® version 5.0 or higher required)

© 2004-2008 Brooks Automation, Inc. All rights reserved.

Instruction Manual

Instruction manual part number 275545

Revision 05 - May 2008