

Power Cable Connections

NOTE: Input phasing sequence = counter-clockwise. Make sure that the lockout procedure (as defined by the facility) has been followed before initiating the following procedure.



CAUTION

Equipment Failure

To avoid equipment failure, use a 10 gauge, 3 conductor cable with ground rating at 600 VAC.

The following procedure provides information for making all three phase (180 - 253 VAC for low voltage or 342 - 528 VAC for high voltage) electrical connections to the Compressor.

1. Cut a 10 AWG (6.00 mm²), 3 conductor cable with ground to an appropriate length.
2. Install a #10 ring tongue terminal on the end of each conductor using the appropriate size double crimping tool.
3. Remove the Rear Panel as shown in *Figure 1*.
4. Remove the System Circuit Breaker Terminal Cover as shown in *Figure 1*.
5. Install the cable into the Compressor through the cable strain relief as shown in *Figure 1*, Detail C.
6. Remove the 10-32 nut and install the grounding wire on the ground stud as shown in *Figure 1*, Detail C. Replace the nut and tighten to 18 in.-lbs (0.21m-kg).
7. Remove the screws from the Compressor circuit breaker terminals X, Y, and Z.

NOTE: The phase order in which the conductor terminal lugs are connected to circuit breaker terminals X, Y and Z will be determined during the Phase Check Procedure. For installation where one of the three phase legs is at or near ground potential, connect that leg to terminal Y on the Compressor.

8. Install the conductor terminal lugs to the circuit breaker terminals X, Y and Z in *Figure 1*, Detail C.
9. Allow enough cable to stay in the circuit breaker area to prevent strain on the electrical connections and tighten the screws on the cable strain relief.
10. Install the power source end of the power cable according to local electrical codes.
11. Install the System Circuit Breaker terminal cover.

Phase Check

1. Apply 200/230, 380/480 VAC power to the On-Board IS Compressor circuit.

NOTE: The System Circuit Breaker (CB1) will trip immediately during step 2 if the power phase connections are not correct.

2. Set the System Circuit Breaker (CB1) to the ON position.
3. If the System Circuit Breaker trips, refer to step 4. If the System Circuit Breaker does not trip, refer to step 5.
4. If the circuit breaker trips, perform the following steps:
 - a. Set the System Circuit Breaker (CB1) to the OFF position.
 - b. Disconnect the power cord from the power source.
 - c. Remove the circuit breaker terminal cover.
 - d. Reverse the wiring order of Compressor circuit breaker terminals X and Y.
 - e. Torque the circuit breaker terminal screws to 12 in.-lbs.
 - f. Install the circuit breaker terminal cover.
 - g. Repeat steps 1- 3 of this procedure.
5. Make sure the Power On indicator is illuminated.
6. Set the System Circuit Breaker (CB1) to the OFF position.
7. Install the rear panel.

Startup

See the 8040647, *On-Board IS Cryopump Operation Instructions*, for details.

Product Information and Technical Support

Please visit the Brooks Automation website at www.brooks.com or email to tscallcenter@brooks.com.

On-Board IS[®] 1000 Compressor Quick Installation Guide

Part Number 8040645, Revision 16, 12/13/2007

ECO Number 18177

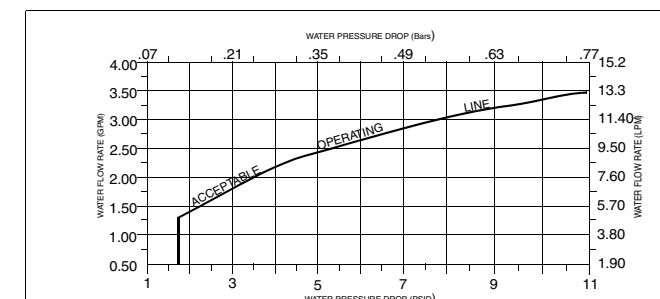
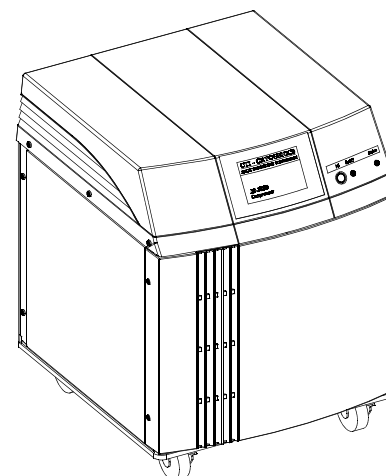

NOTE: This chart defines the water flow rate through the Compressor as a function of the pressure drop from water inlet to water outlet. You must provide the correct pressure drop in your water supply system to ensure that the water flow condition meets the requirements specified.

ON-BOARD IS 1000 COMPRESSOR SPECIFICATIONS

ELECTRICAL	LOW VOLTAGE	HIGH VOLTAGE
OPERATING VOLTAGE RANGE:	180-253 VAC 50/60HZ	342-528 VAC 50/60HZ
PHASE:	3	3
NOMINAL INPUT POWER:	5.8 KW @ 180-208 VAC	5.2 KW @ 460 VAC
RATED FULL LOAD LOCKED ROTOR (FL/LR):	19/85	10/42
MINIMUM ELECTRICAL SERVICE:	30 AMPS	20 AMPS
MAXIMUM INLET TEMPERATURE:	90° F (32° C)	
MINIMUM INLET TEMPERATURE:	50° F (10° C)	
FLOW RATE:	2.75 ±1.25 gpm (10.4 ± 4.7 lpm)	
	NOTE: Refer to user manual for requirements at 60HZ, 375V or lower	
PRESSURE DROP (INLET-TO-OUTLET):	Refer to chart	
MAXIMUM INLET PRESSURE:	100 PSI (6.9 bars)	
ALKALINITY:	6.0 - 8.0 pH	
CALCIUM CARBONATE:	<75 PPM	
DEIONIZED WATER:	Do not use above 100,000 OHM-CM.	
PART NUMBER:	8135921GXXX LV, 8135926GXXX HV	
INPUT POWER CABLE (Customer Supplied):	600 VAC, 10 gauge, 3 Conductor With Ground	
NOMINAL HELIUM PRESSURE:	340 - 350 psig (23.4 - 24.1 bar) @ 60HZ, 355 - 365 psig (24.5 - 25.2 bar) @ 50 HZ	
AMBIENT OPERATING TEMPERATURE:	50 - 100° F(10 - 38° C)	
INTERFACE:	Cryopump power receptacle mates with CTI-Cryogenics supplied cryopump power cable for single pump use. Mates with remote junction box for multiple cryopump use.	
GAS SUPPLY AND RETURN CONNECTOR:	1/2 inch Aeroquip® self-sealing couplings	
REMOTE CONTROL RECEPTACLE:	24 VAC, 2.7A inductive, mates with supplied P5 connector part number MS3106a	
ADSORBER SERVICE SCHEDULE:	3 years	

Before You Start

1. Ensure the On-Board IS Cryopumps are installed according to the appropriate *On-Board IS Cryopump Quick Installation Guide*.
2. Read and follow all safety notices in this guide and in the appropriate compressor guides.

Compressor Safety

Ensure the compressor operates safely and dependably by adhering to all safety notices when you use or service the compressor.



⚠ WARNING

High Voltage

To avoid severe injury or loss of life from high voltage electric shock, turn off all electrical power before proceeding and adhere to all local electrical codes.

Disconnected is when the power entry module is set to OFF, or the power cord is detached from the power entry module.

On-Board IS 1000 Compressor Installation

- 1) Connect **cooling water out** line. Use thread sealant and 1/2 x 14 FNPT with Maximum pressure = 100 psig/6.9 bars. See *Figure 1A* and *Figure 2*.
- 2) Connect **cooling water in** line. See *Figure 1B* and *Figure 2*.
- 3) Connect **helium return** line. See *Figure 1C* and *Figure 5*.
- 4) Connect **helium supply** line. See *Figure 1H* and *Figure 5*.
- 5) Verify the helium pressure. See *Figure 1D* and *Table 1*.
- 6) Connect the **EMO remote** cable, if available. See *Figure 1E* and *Figure 3*.
- 7) Connect the power cable to the **system circuit breaker**. See *Power Cable Connections, Figure 1G*, and *Figure 4*.
- 8) Perform the **Phase Check**. See the Phase Check section in this Guide.
- 9) Connect the logic module. See *Figure 1F* and the *On-Board IS Controller Quick Installation Guide* for instructions.
- 10) Start up the cryopump system. Refer to the *On-Board IS Cryopump System Operation Guide*, CTI-Cryogenics part number 8040647, for instructions about starting the On-Board IS 1000 Compressor and the On-Board IS Cryopump System.

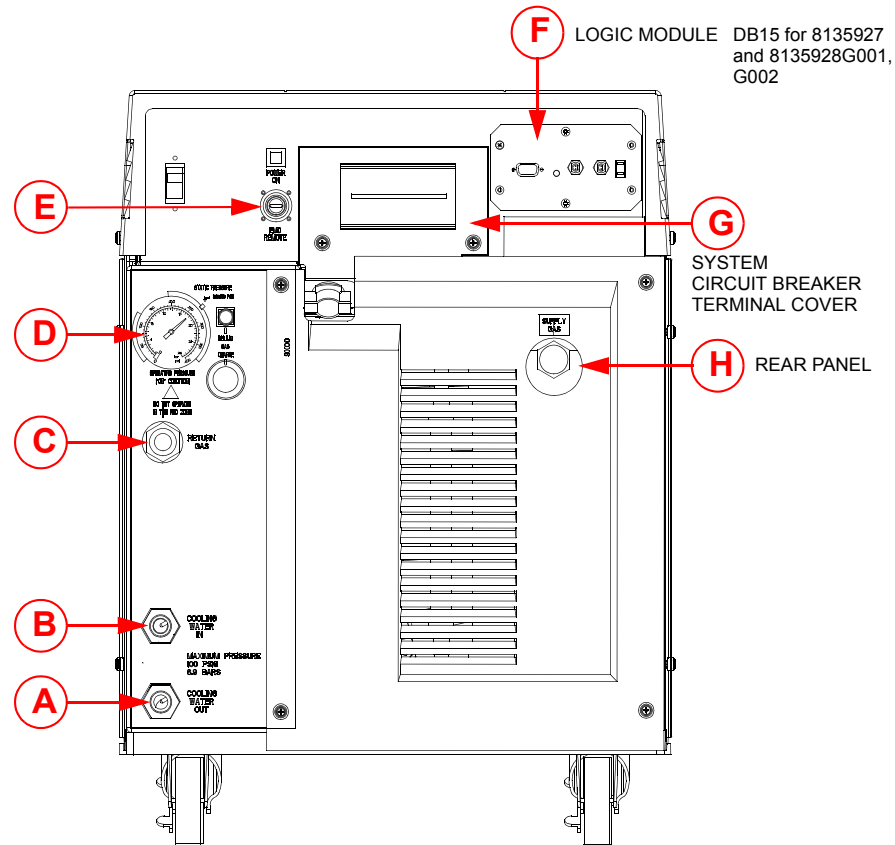

Figure 1: On-Board IS 1000 Compressor Installation Points

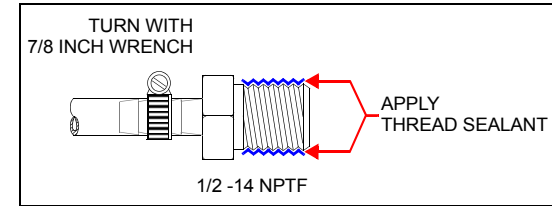

Figure 2: Water Line Connection

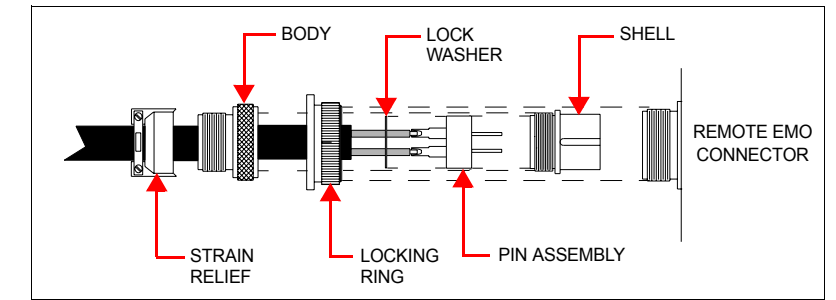

Figure 3: EMO Cable Connections

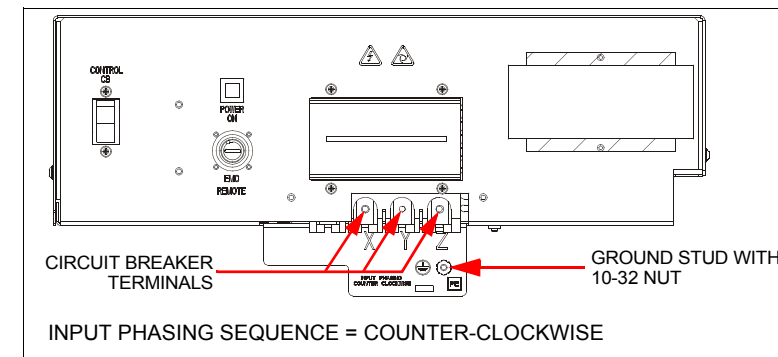

Figure 4: System Circuit Breaker Power Cable Connections

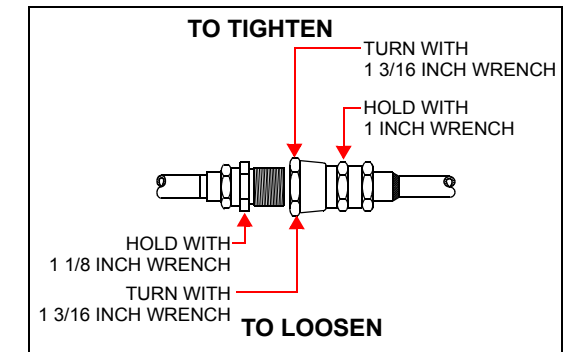

Figure 5: Helium Flex Line Connections

Static Helium System Pressure Verification

The proper static helium system pressure is necessary so that the cryopumps operate at maximum performance as well as to assure that the Compressor operates below the maximum design motor winding temperature. This maximizes the life of the Compressor motor.

1. Make sure the On-Board IS 1000 Compressor and On-Board IS Cryopumps are OFF.
2. Make sure all system helium connections have been made.
3. Allow all system components to acclimate to a temperature between 60° F and 80° F (15.5° C - 26.6° C).
4. Read the Compressor helium pressure gauge located on the Compressor rear panel (see *Figure 1D*). Compare the gauge reading to the appropriate 50/60 HZ line frequency value (depending upon your system installation) indicated in *Table 1*.

Table 1: On-Board IS 1000 Compressor Static Helium System Pressure

Line Frequency	Helium ("OFF" Condition) Charge Pressure
50/60 Hz	340 - 350 psig (23.4 - 24.1 bar)
50 Hz*	355 - 365 psig (24.5 - 25.2 bar)

* This helium charge pressure is only required when supplying helium to six (6) On-Board IS Cryopumps from one On-Board IS 1000 Compressor operating at 50 Hz.